

Track Supply 35 kW

80 / 125 A at 400 / 480 V

Order Number

3090896 (80 A, 400 V, RAL 7035 - lightgrey)

3090899 (80 A, 480 V, RAL 7035 - lightgrey)

3090897 (125 A, 400 V, RAL 7035 - lightgrey)

3090900 (125 A, 480 V, RAL 7035 - lightgrey)

3090901 (Configurable version)



Figure: Type with air conditioning by configurable version 91000-111-3090901



Track Supply 35 kW 80 / 125 A at 400 / 480 V

Contents

1	Understanding.....	5
1.1	Limitation of liability	5
1.2	Copyright	6
1.3	Replacement parts	6
1.4	Material defects	6
1.5	Technical support	6
2	Symbols and Hints	7
3	Advisory Information for the User	8
4	Brief Technical Description	9
5	Appearance and Structure	9
5.1	Type with Air Conditioning.....	9
5.2	Type without Air Conditioning.....	11
6	Technical Data	13
6.1	Electrical Data - Specifications	13
6.1.1	Electrical Output Data – Specifications for 400V and 480V Versions	13
6.1.2	Electrical Input Data – Specifications for 400 V Versions.....	13
6.1.3	Electrical Input Data – specifications for 480 V Versions	14
6.2	Physical Data.....	14
6.2.1	Type without Air Conditioning.....	14
6.2.2	Type with Air Conditioning.....	14
6.3	Environmental Data	15
6.4	Mechanical Data.....	16
6.5	Interfaces.....	18
6.6	General Features.....	18
6.7	Design Standards	19
6.7.1	Design Standards for 400 V Versions (without Air Cond.).....	19
6.7.2	Additional Design Standards for 480 V Versions (without Air Cond.).....	19
6.8	Safety Features of Track Supply	19
6.9	Grounding.....	19

Track Supply 35 kW 80 / 125 A at 400 / 480 V

7	Configuration Options	20
7.1	Configuration with Air Conditioning Unit (mounted on the Side)	20
7.2	Configuration with Industrial Ethernet Interface.....	21
8	Control Board Hardware and Failure Indication.....	24
8.1	Track Supply Control Board	24
8.1.1	Control Board LED Indication	24
8.2	Track Supply Display Board	25
8.2.1	LED indication	25
8.2.2	Software Version Number	27
8.2.3	Modes of Operation.....	27
8.2.4	Setting Language, Time and Date.....	28
8.2.5	Warning Messages.....	29
8.2.6	Error Codes	29
9	Door Switches.....	32
10	Fuses	33
10.1	Mains Semiconductor Fuses	33
10.2	Other Protection Devices (Fuses)	34
11	Transport and Storage	34
12	Installation	35
12.1	Who is authorized to carry out the Installation?.....	35
12.2	General Advice for the Installation.....	35
12.3	Place and Conditions of Installation	36
12.4	Electrical Regulations	37
12.5	Electrical Connection	37
12.5.1	Mains Connection.....	37
12.5.2	Configuration of control plug.....	38
12.5.3	Connection Track Cable (X1)	39
12.5.4	Arrangement external Connections (X1, X2, X3, X5.1).....	39
12.5.5	Wiring of the Track Supply	42
13	Warnings and cautions	43
14	Commissioning	44

Track Supply 35 kW

80 / 125 A at 400 / 480 V

14.1	System conditions	45
14.2	System protection	45
15	Start and operation	46
16	Switching-off	47
17	Actions in case of emergency	47
18	Fault diagnosis	48
19	Maintenance	49
19.1	Safety	49
19.2	Maintenance Schedule Track Supply IP54 (air cooling)	49
19.3	Maintenance Schedule Track Supply IP54 (air cooling)	50
20	Repair	52
21	Disassembly/Re-use	52
21.1	Safety advice for disassembly and disposal	53
21.2	Recycling	53
22	Spare parts	54
23	Tools	56
24	Adjustments during the commissioning and start-up	57
25	Inspection Report	58
26	Additional Documents	59

This Operating Instructions is based on the following Technology-GmbH Documentation-No.: OM9100-0122f-EN!

Important:

Company names mentioned in this manual that are registered and protected trade names by copyright do remain the property of the companies themselves.

We reserve the right to carry out technical modifications of illustrations and statements in these operating instructions, in order to improve the energy supply system and its function.

System related details please find in the system manuals. Refer always to the system documentation before starting any work on the system or components within the system or before operating the system.

Reprint and duplication (as well as extracts) are only allowed with permission from Conductix-Wampfler GmbH.

© Conductix-Wampfler GmbH 2020

Track Supply 35 kW

80 / 125 A at 400 / 480 V

1 Understanding

This document (BAL) describes the component specified on the cover only. The manual does not include details about the interaction of this component with other components within a system.

For information relating to the system please read the system and project documentation. Follow these instructions during any work on the system or operation of the system.

All given values are based on the metric system. Given dimensions without any measuring unit are generally in millimeters (mm).

The unit supplied may vary of the figures shown depending on the configuration. Please check the version delivered selectively from the operation manual!

1.1 Limitation of liability

All data and information in these operating instructions have been compiled while taking the valid standards and regulations as well as the state-of-the art and our many years of experience and knowledge into consideration.

Conductix-Wampfler accepts no liability for damage resulting from:

- Failure to comply with operating instructions
- Improper use
- Use by untrained personnel
- Unauthorized modifications
- Technical changes
- Use of unauthorized replacement parts or accessories

The actual scope of delivery may differ from the explanations and descriptions provided here if the model in question is a special one, if additional equipment has been ordered or due to recent technical changes.

The obligations agreed upon in the delivery agreement and our general terms and conditions of business apply, as do the delivery conditions of Conductix-Wampfler and the legal regulations applicable at the time the contract was concluded.

All products are subject to technical modifications, within the context of improvement of function and further development.

Track Supply 35 kW 80 / 125 A at 400 / 480 V

1.2 Copyright

These operating instructions are subject to copyright, and exclusively intended for internal use by the customer.

Provision of the operating instructions to third parties, reproductions in any form – even in part – as well as the reuse and/or disclosure of their content are not permitted without the written approval of the Conductix-Wampfler, except for the customer's internal use.

Breach or infringement will result in liability for damages. Our right to further claims remains unaffected.

1.3 Replacement parts



WARNING!

Incorrect replacement parts are a safety hazard!

Incorrect or faulty replacement parts can impair safety and result in damage, malfunctions or complete failure.

→ Only use original Conductix-Wampfler replacement parts!

Replacement parts can be ordered an authorized dealer or directly from Conductix-Wampfler.

1.4 Material defects

The terms governing material defects can be found in the General Terms and Conditions of business.

1.5 Technical support

Our customer support staff is available for technical support. See the last page of these operating instructions for contact information.

We are also always interested in new information, experiences and feedback from the field that can help us improve our products.

2 Symbols and Hints



Warning of voltage

This symbol can be found in several places in the operating instructions where special care has to be taken due to a voltage presence which is hazardous to people. Please observe these instructions and be careful in those cases. Please apply all health and safety regulations to other users as well. Always disconnect the system from the main supply prior to carrying out any work on the energy supply system.



Attention - some hints

This sign draws the attention to parts of the operating instructions where the regulations, advice and correct operational sequence must be observed to avoid any damage or destruction to the energy supply system and its components.



Temperature

This sign draws the attention to parts of the operating instructions, where special care must be taken because of hot surfaces or where inductive heating of ferromagnetic material may occur and where special measures have to be taken.

Please pass on the advice to other users as well.

Track Supply 35 kW

80 / 125 A at 400 / 480 V

3 Advisory Information for the User



When the Track Supply is open it can contain live voltage and hot surfaces, depending on its protection class and state of operation.



Non-permissible removal of required covers, improper operation, faulty installation or operation involve risk of severe injuries to a person and damage to components.



The Track Supply has a weight of approx. 280 kg (Type with Air Cond. approx. 370 kg) and must not be lifted or moved by an individual person. To move and position it use only suitable equipment and follow the according instructions (see chapter 6 "Technical data").

All electric installation and commissioning work as well as repair work and disassembly have to be carried out by qualified staff (IEC 364 respectively CENELEC HD 384 or DIN VDE 0100 and IEC 664 or DIN VDE 0110 and national safety rules).

All installation and commissioning work as well as repair work and disassembly have to be done according to the present operation manual. The specifications of this document have to be strictly observed. In addition, national regulations and whenever they apply regulations specific to the industry are to be taken into account.

Qualified staff according to the safety regulations are persons who are familiar with the installation, assembly, commissioning and operation of the energy supply system and who have the appropriate qualifications.

Conductix-Wampfler GmbH cannot be responsible for damage or breakdowns that have been caused by not observing the instruction manual.

These operating instructions contain exclusively details of the Track Supply component.

We reserve the right to carry out technical modifications of illustrations and statements in this instruction manual. References to other documents specifying the document number do not include the revision index. Refer to the project handbook for a list of relevant documents.



NOTE!

Tips and recommendations:

This symbol denotes useful tips and recommendations as well as information for efficient and trouble-free operation.

Track Supply 35 kW

80 / 125 A at 400 / 480 V

4 Brief Technical Description



The Track Supply serves to supply energy to the secondary components of the system in a defined segment. The Track Supply converts the 480 V 60 Hz mains voltage to a constant 20 kHz sinusoidal current. The alternating output current into the primary track of a system produces a local magnetic field over which power is transferred. So the galvanically isolated power transfer to the consumers is possible (e.g. to the pickups).

5 Appearance and Structure

5.1 Type with Air Conditioning

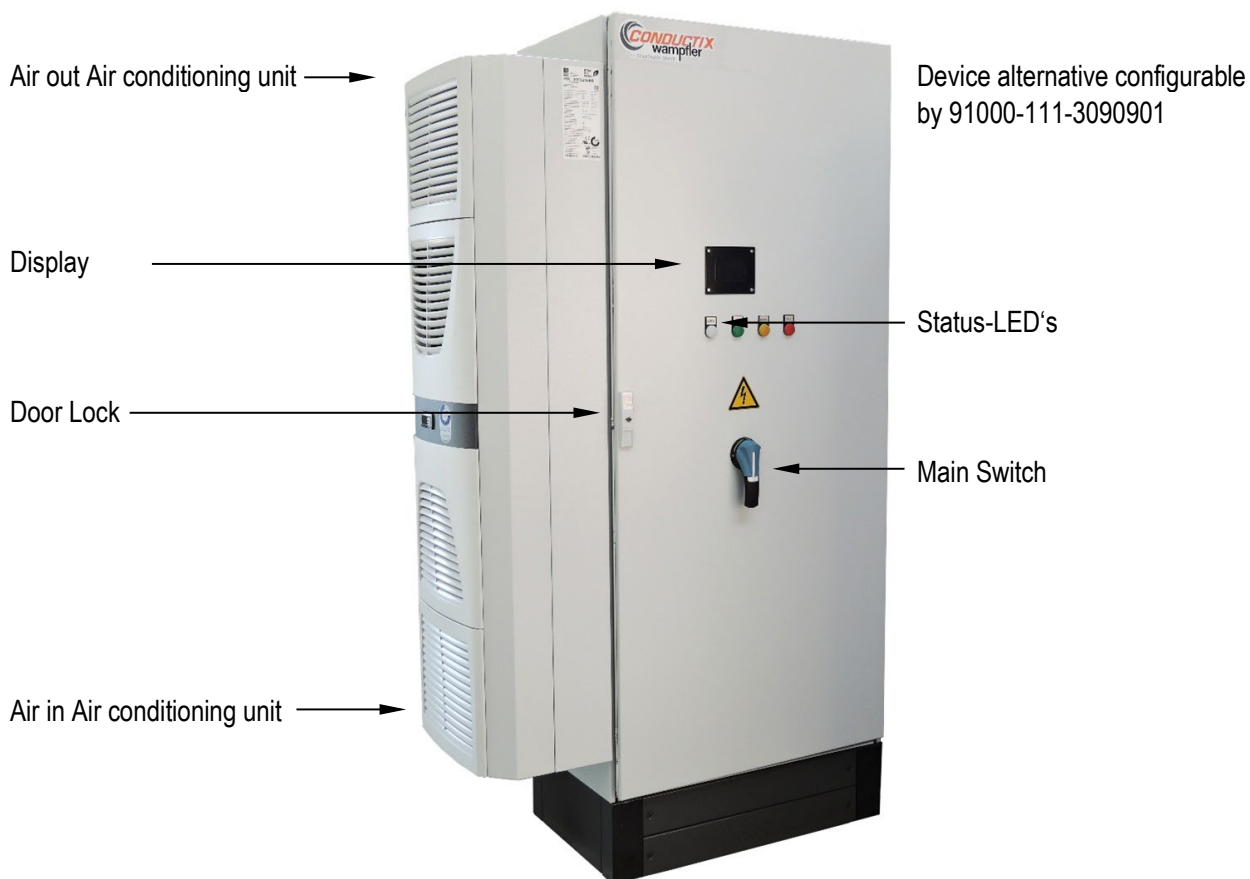

Track Supply 35 kW
80 / 125 A at 400 / 480 V

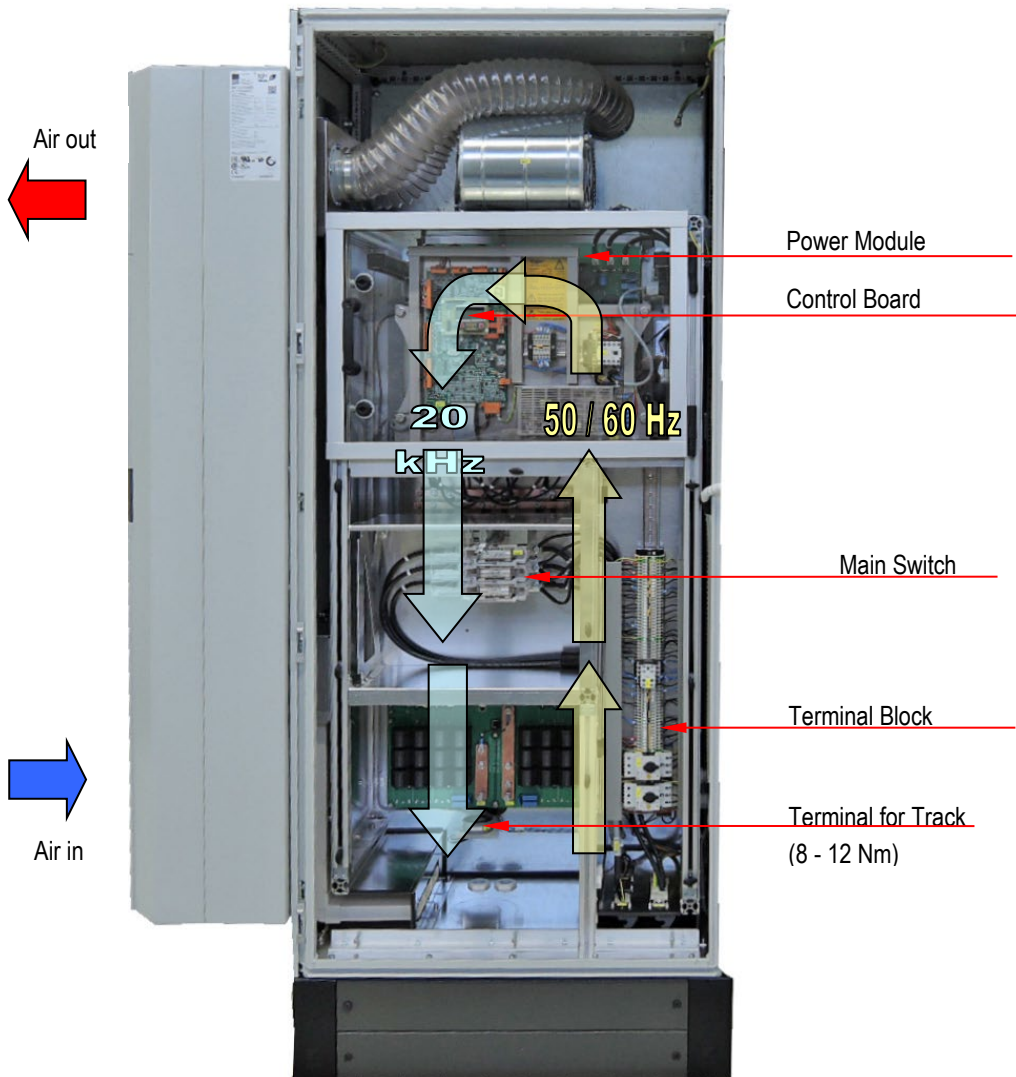

View without the door and without the cover

Regarding the installation place and distances pay attention to the chapter 7 "Optional configurable Air Conditioning Unit (mounted on the Side)"!

Track Supply 35 kW
80 / 125 A at 400 / 480 V

5.2 Type without Air Conditioning

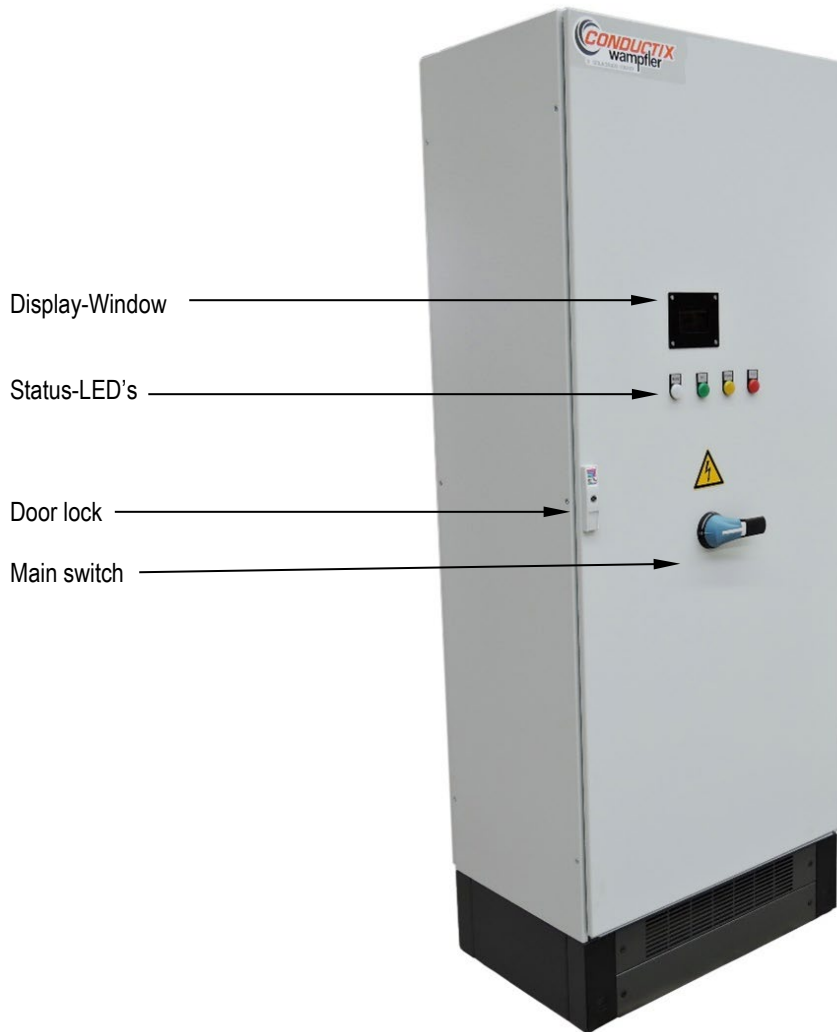

Device alternatives:
3090896 (80 A, 400 V)
3090899 (80 A, 480 V)
3090897 (125 A, 400 V)
3090900 (125 A, 480 V)

Figure: 400 V version

Track Supply 35 kW 80 / 125 A at 400 / 480 V

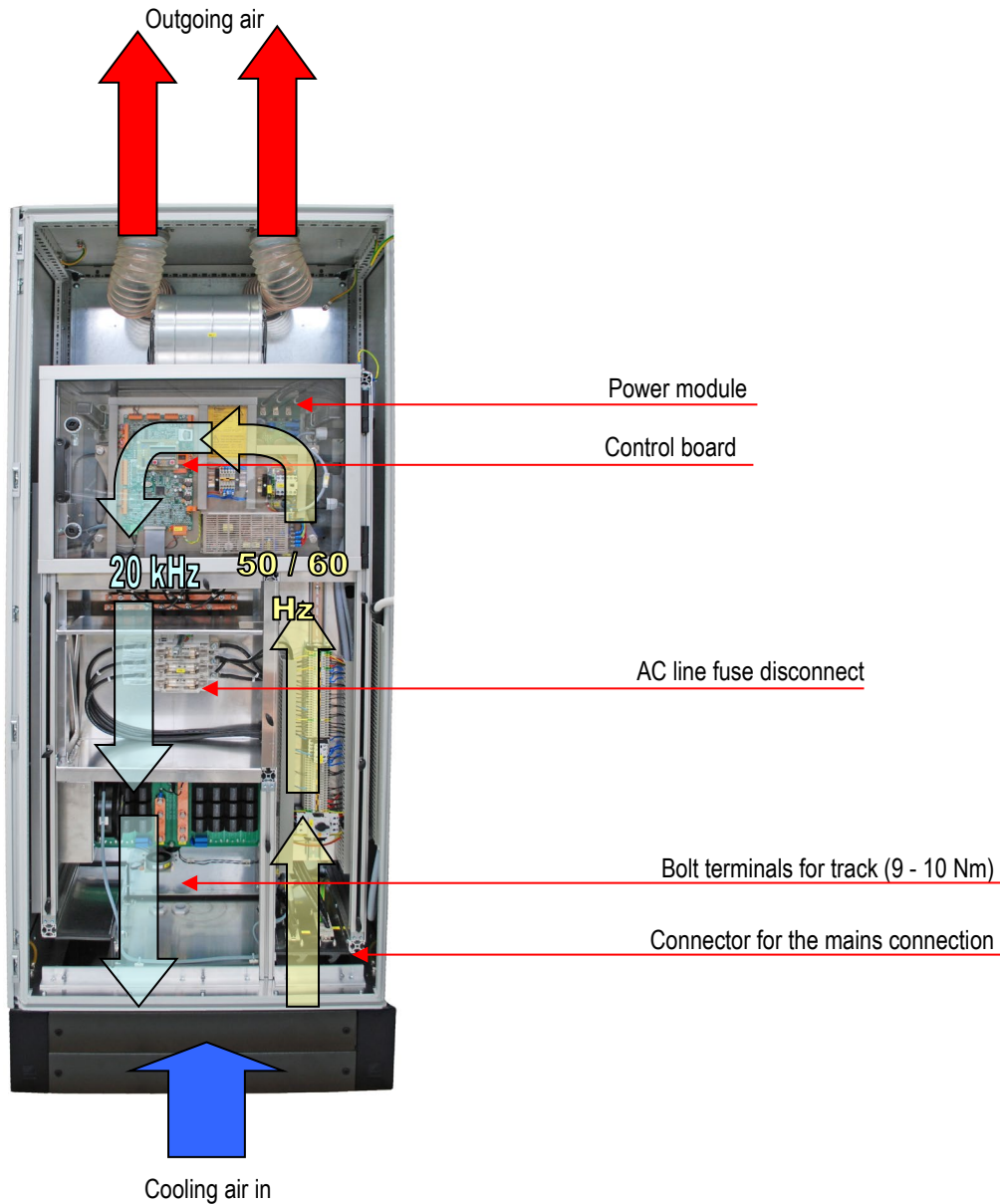

View without the door

Note that the picture above may not in some cases correspond exactly to the delivered component (for example color or wiring positions). If you have concerns you have not been delivered the correct item please contact a Conductix-Wampfler representative.

Track Supply 35 kW 80 / 125 A at 400 / 480 V

6 Technical Data

6.1 Electrical Data - Specifications

6.1.1 Electrical Output Data – Specifications for 400V and 480V Versions

- Continuous output power 35 kW
- Overload capability 137% (48 kW) for max. 1 minute / 10 minute at 40°C, with average load derating to 28kW
- Output current 80A or 125A ± 2 @ 20 kHz ± 50 Hz
- Track inductance for 80 A Track Supply:
58 μ H (target range: 0 to + 2 μ H, possible: -2 to +2 μ H)
for 125 A Track Supply:
26 μ H (target range: 0 to + 2 μ H, possible: -2 to +2 μ H)
- Nominal output voltage range 560 - 750 V rms (80 A), 380 - 520 V rms (125 A).
Overload increases the output voltage value.
- Impedance output to PE 36 Ohm (center capacitively referenced)
- Connection to primary cable Stainless Steel M8 bolts for 35 mm² and 20 mm² HF Litz cables.
Torque range 9-10 Nm.

6.1.2 Electrical Input Data – Specifications for 400 V Versions

- Input supply voltage 400 V / 50 Hz, 3Phase symmetric, neutral grounded
- Supply voltage tolerance +/-10% to + 10%, with proportional cont. power de-rating for input voltages lower than nominal value
- Efficiency at rated load 95%
- Power factor (cos φ) 0.85
- Supply current 65 A at rated load
- Input connector Supplied HAN K6/6 connector with M 40 x 1,5 cable gland.
Maximum outside cable diameter is 25 mm. Use flexible cables recommended.
- Input leakage current 15 mA rms in standby. Typical 80 mA (light load) to 250 mA (full load).
1 A peak currents in the band 20 kHz to 1 MHz. Ground leakage equipment must be rated accordingly if used.
- Internal fuses 80 A (ultra rapid semiconductor) specified in chapter 22
- Harmonic current (rated load) 5th -8 dB, 7th -15 dB, 11th -23 dB, 13th -30 dB

Track Supply 35 kW

80 / 125 A at 400 / 480 V

6.1.3 Electrical Input Data – specifications for 480 V Versions

- Input supply voltage 480 V / 60 Hz, 3 Phase symmetric, neutral grounded
- Supply voltage tolerance +/-10% to + 10%, with proportional cont. power de-rating for input voltages lower than nominal value. See section 14.1 regarding permitted short-term fluctuations and transients.
- Efficiency at rated load 95%
- Power factor (cos φ) 0.85
- Supply current 55 A at rated load
- Input connector Supplied HAN K6/6 connector with M 40 x 1,5 cable gland. Maximum outside cable diameter is 25 mm. Use flexible cables recommended.
- Input leakage current 18 mA rms in standby. Typical 80 mA (light load) to 250 mA (full load). 1 A peak currents in the band 20 kHz to 1 MHz. Ground leakage equipment must be rated accordingly if used.
- Internal fuses 80 A (ultra rapid semiconductor) specified in chapter 22
- Harmonic current (rated load) 5th -8 dB, 7th -15 dB, 11th -23 dB, 13th -30 dB

6.2 Physical Data

6.2.1 Type without Air Conditioning

- Noise levels During operation 57 dBA at 2 m distance in front
- Air volume moved 500 m³ / hour (air recirculation)
- Fan 2 radial fans, 1 axial fan

6.2.2 Type with Air Conditioning

- Air Conditioning Air cond. unit Type Rittal TopTherm SK 3332540
- Fan 1 axial fan (internal air circulation)
- Noise Levels Air. Cond. During operation 65 dBA at 2 m distance in front

Track Supply 35 kW 80 / 125 A at 400 / 480 V

6.3 Environmental Data

- | | |
|---------------------------|--|
| • Ambient temperature | +0°C to +40°C, power de-rating 3% / °C between 40°C and 55°C |
| • Humidity | < 90% non-condensing |
| • Ambient air | No salt water, no conductive dry or wet dust! (e.g. carbon fibers). Avoid extreme environment conditions (e.g. very dusty, Oily and/or chemical influences)! |
| • Altitude de-rating | 1% of power / 100 m above 1000 m, up to a max. of 3000 m above sea level |
| • IP classification | IP 20 (limited by exhaust vents on top) |
| • Storage temperature | -20°C to +60°C |
| • Transport temperature | -20°C to +70°C |
| • Maximum Vibration | 3 mm at 2 - 9 Hz, max. acceleration 0,5 g at 9 - 200 Hz |
| • Maximum operating shock | 8 g, 11 ms |
| • Maximum shipping shock | 15 g, 11 ms in packaging / transport box |

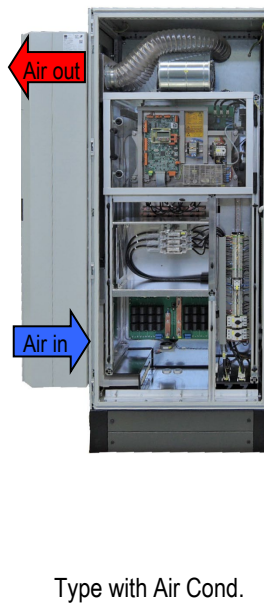

The Track Supply requires for the correct cooling a sufficient air flow. Ensure free air flow at all times and let inspect filters for dust and oil blockage regularly.

The Track Supply has to be fixed on the floor. Follow the instructions of the cabinet producer.

Shielded control cables are not strictly required but to improve the EMC they are recommended.

In order to avoid induced voltages at 20 kHz, the control cables and other cables should not be run close to the track cable and especially not over distances > 5 m. Shielded twisted pair cable will help reduce the capacitive coupling effect. The shield should be grounded at one end only.

- Space around cabinet

A sufficient air flow has to be guaranteed!
Recommended clearances:
400 mm over the Track Supply
400 mm in front of the Track Supply
100 mm sides and back of the Track Supply

Track Supply 35 kW 80 / 125 A at 400 / 480 V

6.4 Mechanical Data

- Cabinet Rittal TS8 or Rittal VX25 with right-hand hinged front door
- Locking Standard locking for Rittal cabinets TS8 or Rittal VX25
- Hinges 130° opening angle
- Dimensions see the following drawing
- Color cabinet (outside) RAL 7035 "lightgrey"
- Color cabinet (inside) RAL 7035 "lightgrey"
- Color base RAL 7022 "umbragrey"
- Weight (without Air Cond.) ~ 280 kg
- Weight (with Air Cond.) ~ 370 kg

Dimensions

3090896 (80 A, 400 V,)

3090897 (125 A, 400 V,)

3090899 (80 A, 480 V,)

3090900 (125 A, 480 V,)

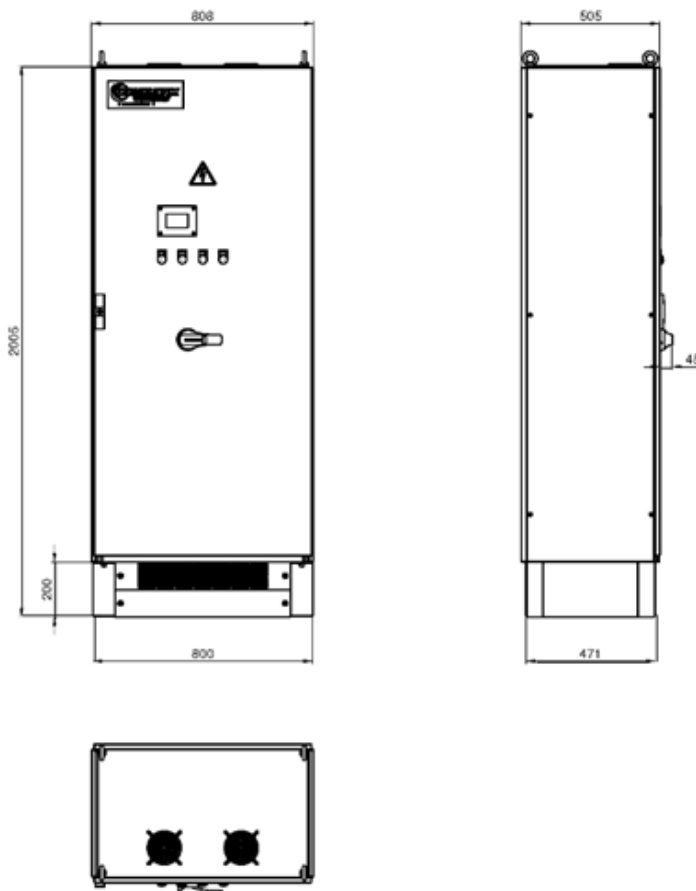

Dimensions type without Air Cond.

Track Supply 35 kW
80 / 125 A at 400 / 480 V

3090901 (configurable, with air condition unit)

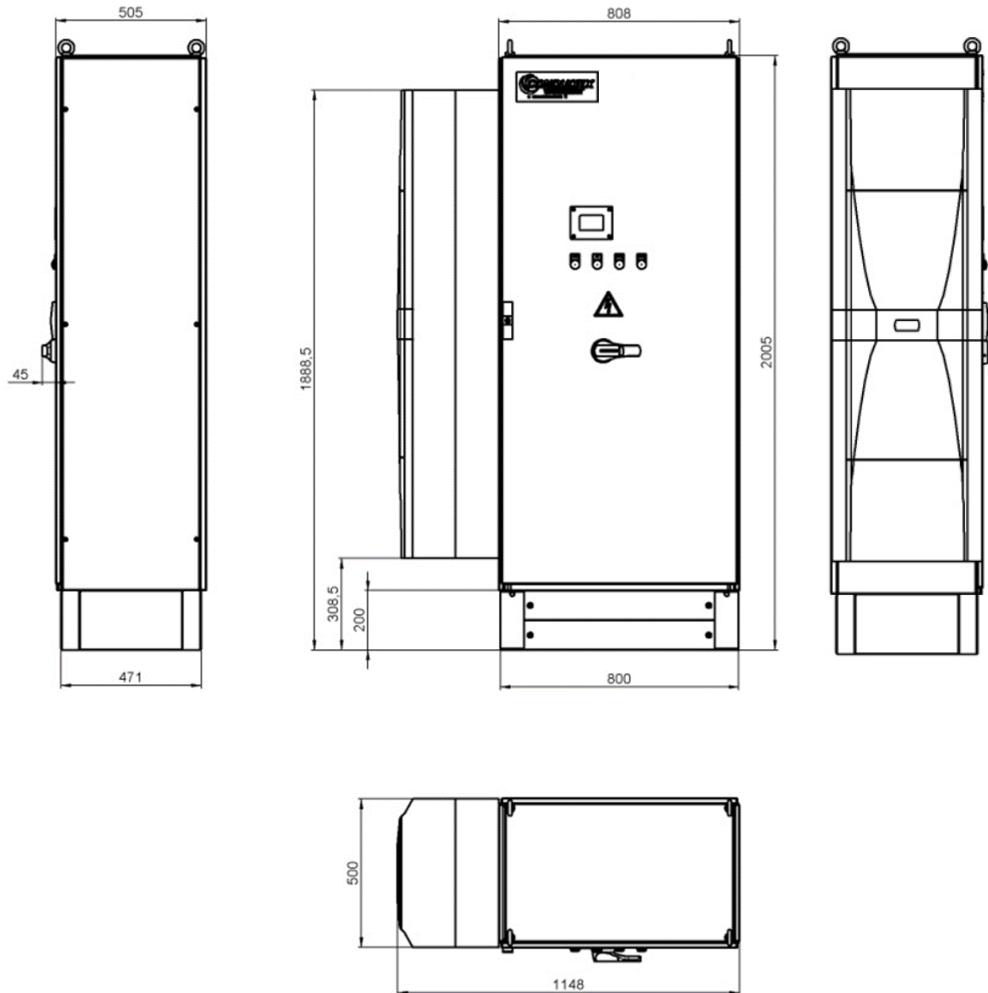

Dimensions type with Air Condition Unit

Track Supply 35 kW

80 / 125 A at 400 / 480 V

6.5 Interfaces

Track connection (X1)

Pin	Function	Remarks
1	Track cable 1	Up to 35 mm ² lug soldered HF Litz cable *
2	Track cable 2	

* = cable shoes with M8 hole!

Connection to AC mains supply (X2); Harting HAN K6/6

Pin	Function	Rating	Remarks
1	L1	80 A	I depending on load
2	L2	80 A	I depending on load
3	L3	80 A	I depending on load
PE	PE		

Control and synchronization (X3); Harting HAN 10

Pin	Function	Rating	Remarks
1	Start +	24 V	24 V present = start
2	Start -	0 V	
3	/Reset +	24 V	0 V = reset
4	/Reset -	0 V	
5	Error Relay	1 A	Normally closed, open on error
6	Error Relay	24 V	
7	24 V supply	100 mA	Not for external distribution!
8	0 V		
9	Synchronization	±15 V	
10	Synchronization		

Industrial Ethernet Interface (X5.1), RJ45; device: Han PushPull PFT plastic Bulkhead (Harting no. 09352250331), cable: Han PP V14 RJ45 (Harting no. 09352210421)

For the track supply model 9100-111-3090901 (configurable version) an optional Industrial Ethernet Interface is available. For more details see chapter 7.2.

For more details on X1, X2, X3 and X5.1 and their connection refer to chapter 12.5 "Electrical connection".

6.6 General Features

- Input line chokes will drop 4% from the mains voltage at rated load
- EMC filtering Built in line filter included
- Start-up inrush current < 10 A
- Mains to output isolation High frequency isolation transformer
- Internal cooling fans 2 blower fans, 1 axial heat exchange fan

Track Supply 35 kW

80 / 125 A at 400 / 480 V

6.7 Design Standards

6.7.1 Design Standards for 400 V Versions (without Air Cond.)

- EN 50178 Electronic equipment for use in power installations; German version EN 50178: 1997
- EN 61000-6-2 Electromagnetic compatibility (EMC) – Part 6-2: Generic standards – Immunity for industrial environments
- EN 55011 Industrial, scientific and medical (ISM) radio-frequency equipment Radio disturbance characteristics – Limits and methods of measurements (IEC/CISPR 11:1997)

6.7.2 Additional Design Standards for 480 V Versions (without Air Cond.)

- UL 508A Standards for Industrial Control Panels

6.8 Safety Features of Track Supply

- Over temperature 4 In-built temperature sensors and switches
- Over load Output load monitoring
- Over current Internal current monitoring
- Over voltage on input Built-in varistors to protect semiconductors from external voltage transients (see section 14.1)
- Overvoltage on output Output voltage control
- Ground fault detection Leakage current monitoring
- Current sensor failure detect Fault detection in case feed sensors are not functioning correctly
- Track detuning Monitors track and detects if the tuning is out of range
- Input line loss Detects if line phase is missing
- Input to output isolation 2500 V AC for 1 min
- Electrical contact Internal protective polycarbonate covers behind door
- Door interlock Electricity removed when door is opened
- Fuses 80 A Ultra rapid semiconductor types (see chapter 22)

6.9 Grounding

The Track Supply must be grounded by technicians at the installation location, preferably to a three-phase grid with a grounded neutral point. Other connection variants, such as delta grounding, can lead to excessive EMC values and should therefore not be used.

Metal structures which run close and parallel to the primary track cable over significant distances have to be grounded professionally too. For best results multiple grounding should be applied. In order to avoid induced voltages at 20 kHz, the control cables and other cables should not be run close to the track cable and especially not over distances > 5 m. Shielded twisted pair cable will help reduce the capacitive coupling effect, but the shield should be grounded at one end only.

Track Supply 35 kW 80 / 125 A at 400 / 480 V

7 Configuration Options

7.1 Configuration with Air Conditioning Unit (mounted on the Side)

The air conditioning unit is located on the left side of the track supply. Pay attention to the recommended distances to the neighboring equipment or walls (min. 400 mm) to ensure a free air flow (see chapter 5 „Appearance“ and 6.4 “Environmental Data”). Regarding the operation and maintenance of the air conditioning unit follow the producer documentation.

Mounted Air Conditioning Unit:



RITTAL
GmbH & Co. KG
Auf dem Stützelberg
D - 35745 Herborn

RITTAL TOP THERM

SK 3332540
Schaltschrank - Kühlgerät
Enclosure Cooling Unit
Climatiseur pour armoires électriques

Spannungsbereich/Voltage range 400V/480V
Frequenzbereich/Frequency range 50Hz/60Hz

	400 V/50 Hz 3~	480V/60 Hz 3~
Bemessungsstrom Rated current	3,8 A	3,9 A
Anlaufstrom Starting current	9,2 A	11 A
Motorschützenschalter Motor protecting switch	10 A	10 A
Bemessungsaufnahme Nominal refrigeration capacity	L35 L35 , 1710W	2110W
Nutzkühlleistung Useful cooling output DIN 3168/EN 814	L35 L50 , 1980W	2450W
Kältemittel/Füllgewicht Refrigerant/Charge	L35 L35 , 4000W	4400W
Zul. Druck (PS) HD/ND allowable pressure (PS)HP/LP	L35 L50 , 3070W	3570W
Temperaturbereich Temperature range	R134a 3000g Fluid Group 2	
Geräuschpegel Noise level	HD/HP 28 bar ND/LP 18 bar	
Schutzart EN 60529 IP Code	Min/Max TO 20 - 55 °C	
Innenkreislauf Internal circuit	65 dB(A)	
Außenkreislauf External circuit	IP 54	
Gewicht Weight	IP 34	
Datum Date	91 kg	
Fabr.-Nr. Production No.	26.04.06	
	D 3304	
	DICHTHEIT GEPRÜFT Leakage tested EN 378-2	

RWTÜV GS
Geprüft nach EN 378-2

Recommended adjustment of the temperature for the operation – according to the specified operation conditions:
35 °C

In case an exchange of the air conditioning unit is needed follow the producer documentation and attend to the correct polarity of the connections.

Track Supply 35 kW

80 / 125 A at 400 / 480 V

7.2 Configuration with Industrial Ethernet Interface

For the Track Supply model 9100-111-3090901 (configurable version) an optional Industrial Ethernet Interface is available. The Ethernet interface (-5X1) is located at the bottom of the Track Supply. If a Track Supply with this option is ordered, the matching (external) plug is supplied for connection to -5X1.

Plug type: PLUG CONNECTOR RJ45 CAT5 IP65 SHIELDED (Han PP V14 RJ45 Cat5 Stvb 4p IDC 6.5-9.5)

An example a PROFINET project including manual (TI9100-0075) for the integration into an existing PLC project can be downloaded from Conductix-Wamplfer homepage. The documents are compressed in a password-protected ZIP archive. The password can be obtained from Conductix-Wamplfer GmbH.

The example project is tested and implemented with following hardware:

- Siemens Simatic Step7 V5.5 + SP4 K5.5.4.0
- Siemens CPU 314C-2 PN/DP V3.3
- HMS Anybus Communicator AB7013-C / V3.03 (PROFINET)

Description of the Software Interface

Declaration	Name	Type	Comment
Input	I_RemoteStart	BOOL	Remote start signal
Input	I_RemoteReset	BOOL	Remote reset signal
Input	LADDR_Input_1	WORD	Peripheral starting-address for function DPRD_DAT of input_1
Input	LADDR_Input_2	WORD	Peripheral starting-address for function DPRD_DAT of input_2
Input	LADDR_Input_3	WORD	Peripheral starting-address for function DPRD_DAT of input_3
Input	LADDR_Input_4	WORD	Peripheral starting-address for function DPRD_DAT of input_4
Input	LADDR_Input_5	WORD	Peripheral starting-address for function DPRD_DAT of input_5
Input	LADDR_Input_6	WORD	Peripheral starting-address for function DPRD_DAT of input_6
Input	LADDR_Output_1	WORD	Peripheral starting-address for function DPWR_DAT of output_1
Output	RemoteStart	BOOL	Feedback from remote start signal
Output	RemoteReset	BOOL	Feedback from remote reset signal
Output	LocalStart	BOOL	Feedback from local start signal
Output	LocalReset	BOOL	Feedback from local reset signal
Output	DIP1	BOOL	Feedback DIP-Switch 1 on TSCB
Output	DIP2	BOOL	Feedback DIP-Switch 2 on TSCB
Output	DIP3	BOOL	Feedback DIP-Switch 3 on TSCB
Output	DIP4	BOOL	Feedback DIP-Switch 4 on TSCB
Output	OVERLOAD_WARNING	BOOL	
Output	OVERTEMP_WARNING	BOOL	

Track Supply 35 kW

80 / 125 A at 400 / 480 V

Declaration	Name	Type	Comment
Output	RTC_WARNING	BOOL	
Output	TUNING_WARNING	BOOL	
Output	INIT_STATE	BOOL	
Output	DISABLED_STATE	BOOL	
Output	BOOT_STATE	BOOL	
Output	ENABLED_STATE	BOOL	
Output	ERROR_STATE	BOOL	
Output	SUSPENDED_STATE	BOOL	
Output	SHUTDOWN_STATE	BOOL	
Output	DS1820_Temp1	INT	Temperature in [°C]
Output	DS1820_Temp2	INT	Temperature in [°C]
Output	NTC_Temp1	INT	Temperature in [°C]
Output	NTC_Temp2	INT	Temperature in [°C]
Output	Query_Count	INT	Number of requests from ABC to TSCB
Output	Response_Count	INT	Number of answers from TSCB to ABC
Output	Errorcode	INT	See manual
Output	E001	BOOL	Error phase loss
Output	E002	BOOL	Error IGBT
Output	E003	BOOL	Error internal current hardware limit
Output	E004	BOOL	Error ground fault
Output	E005	BOOL	Error door open
Output	E006	BOOL	Error no track current
Output	E007	BOOL	Error temperature high on sensor 1
Output	E008	BOOL	Error temperature high on sensor 2
Output	E009	BOOL	Error temperature sensor 1 defect
Output	E010	BOOL	Error temperature sensor 2 defect
Output	E011	BOOL	Error temperature high on heat sink sensor 1
Output	E012	BOOL	Error temperature high on heat sink sensor 2
Output	E013	BOOL	Error heat sink temperature sensor 1 short circuited
Output	E014	BOOL	Error heat sink temperature sensor 1 open circuited
Output	E015	BOOL	Error heat sink temperature sensor 2 short circuited
Output	E016	BOOL	Error heat sink temperature sensor 2 open circuited
Output	E017	BOOL	Error temperature switch 1 open circuited
Output	E018	BOOL	Error temperature switch 2 open circuited
Output	E019	BOOL	Error LCD
Output	E020	BOOL	Error output track voltage high
Output	E021	BOOL	Error output track current high
Output	E022	BOOL	Error output power high
Output	E023	BOOL	Error soft-start

Track Supply 35 kW 80 / 125 A at 400 / 480 V

Declaration	Name	Type	Comment
Output	E024	BOOL	Error watchdog
Output	E025	BOOL	Error brownout
Output	E026	BOOL	Error track supply output open circuited
Output	E027	BOOL	Error DC bus voltage high
Output	E028	BOOL	Error DC bus voltage low
Output	E029	BOOL	Error internal current software limit
Output	E030	BOOL	Error DC bus voltage unstable
Output	E031	BOOL	Error inductance high
Output	E032	BOOL	Error inductance low
Output	E033	BOOL	Error 3.3V on board power supply failure
Output	E034	BOOL	Error 3.3V on board power supply failure
Output	E035	BOOL	Error 3.3V on board power supply failure
Output	E036	BOOL	Error 3.3V on board power supply failure
Output	E037	BOOL	Error 5V on board power supply failure
Output	E038	BOOL	Error 24V control board supply failure
Output	E039	BOOL	Error FPGA configuration
Output	E040	BOOL	Error FPGA SPI bus
Output	E041	BOOL	Error invalid output voltage measurement
Output	E042	BOOL	Error invalid output current measurement
Output	E043	BOOL	Error invalid internal current measurement
Output	E044	BOOL	Error oscillator
Output	E045	BOOL	Error FPGA software
Output	E046	BOOL	Error zone controller 1
Output	E047	BOOL	Error zone controller 2
Output	E048	BOOL	Error DIP switch
Output	E049	BOOL	Error output peak power high
Output	ret_val_input_1	INT	Error-code from function DPRD_DAT for input_1
Output	ret_val_input_2	INT	Error-code from function DPRD_DAT for input_2
Output	ret_val_input_3	INT	Error-code from function DPRD_DAT for input_3
Output	ret_val_input_4	INT	Error-code from function DPRD_DAT for input_4
Output	ret_val_input_5	INT	Error-code from function DPRD_DAT for input_5
Output	ret_val_input_6	INT	Error-code from function DPRD_DAT for input_6
Output	ret_val_output_1	INT	Error-code from function DPWR_DAT for output_1

Track Supply 35 kW
80 / 125 A at 400 / 480 V

8 Control Board Hardware and Failure Indication

8.1 Track Supply Control Board

The control board is located in the upper part of the Track Supply and is visible if the door of the cabinet is open.

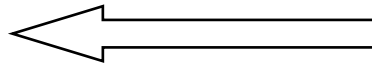

There are two PCB's :

- The control board
- The display board sitting on top of the control board → refer to chapter 8.2

8.1.1 Control Board LED Indication

The control board LED's are normally only visible when the door is open and/or the protective covers have been removed. Therefore these LED's are intended for advanced error analysis only.

The two green LED's (V503 and V504) indicate the correct functioning of the on-board power supplies (12V and 5V) and should always be on.

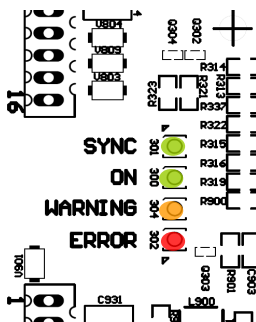

The 4 LED's on the control board inform the user of the state of operation of the Track Supply:

- SYNC (green LED)
- ON (green LED)
- WARNING (yellow LED)
- ERROR (red LED)

The indication of the 'On', 'Warning' and 'Error' LED's corresponds to the one of the three LED's located on the Track Supply display board (refer to section 8.2.1).

In addition the 'Sync' LED indicates whether an external 20 kHz synchronization signal is present or not.



Only replace with a battery of the same type! The use of different batteries can lead to material damage, fire, or explosion.

Track Supply 35 kW
80 / 125 A at 400 / 480 V

8.2 Track Supply Display Board

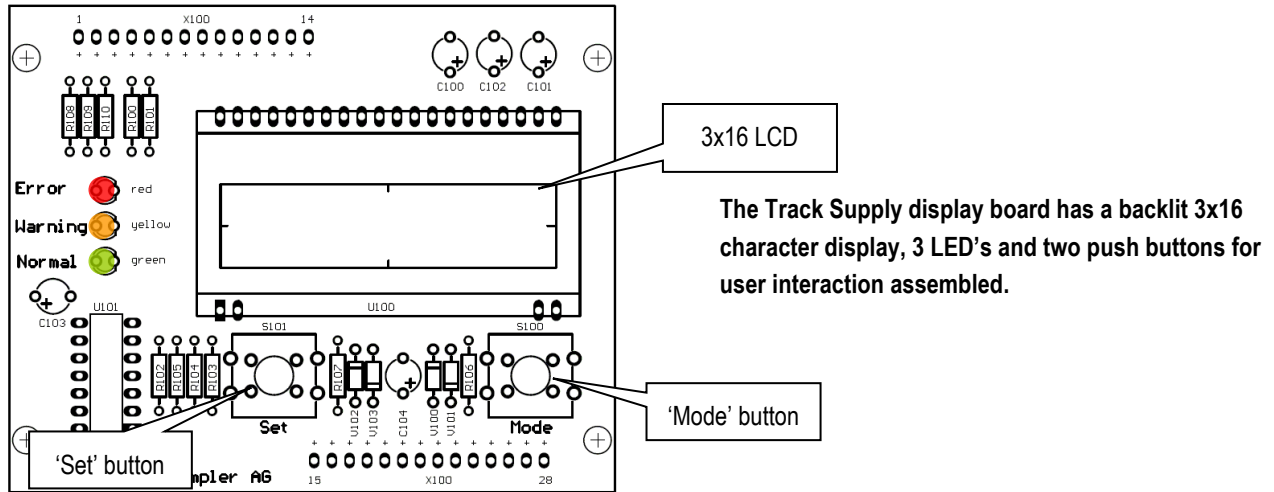



8.2.1 LED indication

The behavior of the three display board LED's is as follows:





LED green	Status	Cause
Off	Track Supply not powered or error → see red LED	Possible causes: <ul style="list-style-type: none"> Track Supply is disconnected from the mains power Problem with control board
Flashing	Track Supply in standby mode	Normal condition due to absence of START signal on X3
On	Track Supply is running	Normal condition: START and RESET signals are present on X3

Track Supply 35 kW

80 / 125 A at 400 / 480 V

LED red	Status	Cause
 Off	Track Supply not powered or no error → see green LED	Normal condition if there is no error.
 Flashing	Track Supply in reset mode	Normal condition due to absence of RESET signal on X3
 On	Track Supply error → see yellow LED / LCD	See display for error code. Error codes are described in section 8.2.6 below.

The yellow LED warns the user of critical operating conditions. No warning will stop operation of the Track Supply, however, a persistent warning may subsequently lead to an error if left unattended. If more than warning is present at a time, only the most important one will be shown (in the table below importance increases from top to bottom). Example: if tuning and overload warning both are present, the warning LED will be on. The LCD, however, will display both warnings (see section 8.2.5).

LED yellow	Status	Cause
 Off	No warnings	
 1 brief flash every 2s	Real Time Clock warning	Real Time Clock has stopped due to weak battery and may be out of date. Track Supply will continue to operate, however, errors will no longer be time stamped correctly.
 2 brief flashes every 2s	Tuning warning	Track inductance is too low or too high. Track Supply can continue to operate, however, an over temperature condition may result. Causes: <ul style="list-style-type: none"> • Incorrect commissioning • Pickups added after commissioning • Damaged track tuning capacitors • Track/ Feeds repositioned or lengthened
 Flashing slowly	Over temperature warning	One or more of the following causes: <ul style="list-style-type: none"> • Air intake or exhaust blocked • Fan(s) blocked by dust or defect • Heat sink blocked by dust • Overloading, too many loads • Ambient temperature too high Track Supply will continue to operate, however, an over temperature condition may result.
 On	Overload warning	Too many loads on track. Track Supply will continue to operate, however, an over temperature, over current or over voltage condition may result.

Track Supply 35 kW

80 / 125 A at 400 / 480 V

8.2.2 Software Version Number

After powering up the LCD displays for 5 seconds a welcome screen with software revision number and compilation time and date.

The Track Supply may start operation prior to the expiry of 5s delay depending on the START input.

```
Version 1234567a
13:07
17-Mai-09
```

8.2.3 Modes of Operation

During operation the LCD provides basic information about the operating mode of the Track Supply. The following modes have been defined:

The Track Supply is powered but does not receive a high level signal on its RESET input. Output is disabled.

```
-----RESET-----
No warnings
```

The Track Supply is powered but does not receive a high level signal on the START input. Output is disabled.

```
-----STANDBY-----
No warnings
```

The Track Supply is operating normally.

```
-----RUN-----
No warnings
```

The Track Supply detected an error. Error code with time and date of occurrence are displayed. Refer to section 8.2.6 below for details on error codes
Output is disabled.

```
-----ERROR-----
E001          15:01
                26.05.09
```

Track Supply 35 kW 80 / 125 A at 400 / 480 V

8.2.4 Setting Language, Time and Date

There are two buttons located beneath the LCD that allow the user to change basic settings. Settings may be changed in any mode, except in RESET mode. If the RESET mode is entered (RESET input low) while settings are being changed, any changes made are lost!

To start changing settings, the MODE key must be held down for 5 seconds. Once this delay has expired the right hand screen will be displayed. Subsequent presses of the SET key will step through the four available display languages:

- English
- German
- French
- Italian

Pressing the MODE key will advance to the next setting screen shown below.

```
SELECT LANGUAGE
English
```

The time setting is displayed in 24h hh:mm format. The keys function as follows:

- Pressing or holding the SET key will increase the setting marked by the cursor.
- Pressing the MODE key will advance the cursor to the minute setting or the next screen respectively.

```
SET TIME
15:01
hh:mm
```

The date is displayed in dd.mm.yy format. The keys function as follows:

- Pressing or holding the SET key will increase the setting marked by the cursor.
- Pressing the MODE key will advance the cursor to the next setting or the next screen respectively.

```
SET DATE
26:05.09
dd:mm:yy
```

If any changes were made, the user is prompted to confirm or discard these.

- Pressing the MODE key will discard any changes.

```
SAVE ?
Yes           No
```

- Pressing the SET key will save the new settings, which is confirmed by the right hand screen.

```
Settings saved!
```

Track Supply 35 kW

80 / 125 A at 400 / 480 V

8.2.5 Warning Messages

While the Track Supply is in modes RESET, STANDBY and RUN, additional warning messages may be displayed. These are displayed by the state of the yellow LED. If more than one warning is present at a time, warning messages will alternate every second. The following warning messages are available:

- No warnings
- Warning Over load (Overload)
- Warning Over Temperature (Overtemp)
- Warning Tuning
- Warning RTC

Refer to section 8.2.1 for a detailed description and possible causes.

8.2.6 Error Codes

Note that one and the same problem can lead to different error codes, depending on the time of occurrence. This is because the error detection methods and reaction times differ for each type of error and also due to the mainly sequential processing by the microprocessor. Once an error is detected, subsequent errors are ignored.

Error code	Description	Meaning/Cause
E001	Phase loss	<ul style="list-style-type: none">• Input line phase missing or weak• Blown line fuse(s)• Fuse receptacle is not shut or screwed down properly
E002	IGBT error	<ul style="list-style-type: none">• IGBT or IGBT driver board defective• EMC disturbance• 400V TS used on 480V supply
E003	Internal current hardware limit	<ul style="list-style-type: none">• High peak load• Track cable is broken or not connected• Track tuning defective
E004	Ground fault	<ul style="list-style-type: none">• Isolation of Track Supply or track installation damaged.• Water present on track• Ground fault level set too low.
E005	Door open	<ul style="list-style-type: none">• Pins 11 and 12 of X104 not bridged• Loose contact

Track Supply 35 kW

80 / 125 A at 400 / 480 V

Error code	Description	Meaning/Cause
E006	No track current	<ul style="list-style-type: none"> Track current sensor defect or wire broken
E007	Temperature high on sensor 1	<ul style="list-style-type: none"> Air intake or exhaust blocked Overloading, too many loads Ambient temperature too high Damaged track tuning capacitors Axial fan defect / Fan fuse blown
E008	Temperature high on sensor 2	See E007
E009	Temperature sensor 1 defect	<ul style="list-style-type: none"> Defect sensor Loose connection
E010	Temperature sensor 2 defect	<ul style="list-style-type: none"> Defect sensor Loose connection
E011	Temperature high on heat sink sensor 1	See E007
E012	Temperature high on heat sink sensor 2	See E007
E013	Heat sink temperature sensor 1 short circuited	<ul style="list-style-type: none"> Temperature sensor wiring problem
E014	Heat sink temperature sensor 1 open circuited	<ul style="list-style-type: none"> Temperature sensor wiring problem
E015	Heat sink temperature sensor 2 short circuited	<ul style="list-style-type: none"> Temperature sensor wiring problem
E016	Heat sink temperature sensor 2 open circuited	<ul style="list-style-type: none"> Temperature sensor wiring problem
E017	Temperature switch 1 open circuited	<ul style="list-style-type: none"> Loose connection See E007
E018	Temperature switch 2 open circuited	<ul style="list-style-type: none"> Loose connection See E007
E019	LCD	<ul style="list-style-type: none"> LCD defect Loose connection between display and control boards
E020	Output (Track) voltage high	<ul style="list-style-type: none"> Track is detuned
E021	Output (Track) current high	<ul style="list-style-type: none"> Control board failure
E022	Output power high	<ul style="list-style-type: none"> Too many pickup loads on track
E023	Soft-start error	<ul style="list-style-type: none"> Soft-start circuit failure
E024	Watchdog	<ul style="list-style-type: none"> Software problem
E025	Brownout	<ul style="list-style-type: none"> Control board supply voltage failure Control board on-board power supply failure
E026	Track Supply output open circuited	<ul style="list-style-type: none"> Track not connected Track cable damaged or cut
E027	DC bus voltage high	<ul style="list-style-type: none"> Mains over voltage, e.g. lightning or other disturbance
E028	DC bus voltage low	<ul style="list-style-type: none"> Phase of mains supply missing, e.g. fuse blown Weak mains supply
E029	Internal current software limit	<ul style="list-style-type: none"> High peak load Track is open circuited Track is detuned

Track Supply 35 kW

80 / 125 A at 400 / 480 V

Error code	Description	Meaning/Cause
E030	DC bus voltage unstable	<ul style="list-style-type: none"> At power up no stable DC bus voltage could be detected due to a mains supply disturbance
E031	Inductance high	<ul style="list-style-type: none"> Track tuning capacitor aging, failure or loose connection inside capacitor box Incorrect commissioning Pickups added after commissioning Track/ Feeds repositioned or lengthened after commissioning
E032	Inductance low	<ul style="list-style-type: none"> Track tuning capacitor aging, failure or loose connection inside capacitor box Incorrect commissioning Pickups added after commissioning Track/ Feeds repositioned or lengthened after commissioning
E033	3.3V on board power supply failure	<ul style="list-style-type: none"> Communication power supply overload/failure
E034	3.3V on board power supply failure	<ul style="list-style-type: none"> Micro power supply overload/failure
E035	3.3V on board power supply failure	<ul style="list-style-type: none"> Analog power supply overload/failure
E036	3.3V on board power supply failure	<ul style="list-style-type: none"> FPGA power supply overload/failure
E037	5V on board power supply failure	<ul style="list-style-type: none"> 5V power supply overload/failure
E038	24V control board supply failure	<ul style="list-style-type: none"> 24V power supply overload/failure 24V on external Han 10 being used inappropriately
E039	FPGA configuration error	<ul style="list-style-type: none"> FPGA failure Flash memory failure SPI bus problem
E040	FPGA SPI bus error	<ul style="list-style-type: none"> SPI bus problem
E041	Invalid output voltage measurement	<ul style="list-style-type: none"> FPGA failure
E042	Invalid output current measurement	<ul style="list-style-type: none"> FPGA failure
E043	Invalid internal current measurement	<ul style="list-style-type: none"> FPGA failure
E044	Oscillator error	<ul style="list-style-type: none"> Micro oscillator failure
E045	FPGA software error	<ul style="list-style-type: none"> Software not compatible
E046	Zone controller 1 error	<ul style="list-style-type: none"> Zone controller fault report (external)
E047	Zone controller 2 error	<ul style="list-style-type: none"> Zone controller fault report (external)
E048	DIP switch	<ul style="list-style-type: none"> Wrong DIP-switch setting
E049	Output peak power high	<ul style="list-style-type: none"> See E022; too many loads on the track or power demand too high

9 Door Switches



Main door switch – shown in "OFF" position (exact orientation of the switch may vary).

Functions of the main door switch:

Function 1: Isolates the inverter stage of the Track Supply, thus disconnecting the output from power even when a start signal is applied.

Function 2: Only in the "OFF" position can the cabinet door be opened!



If the main switch is placed in the "OFF" position, parts of the Track Supply may still be live. Various types of damage can occur. The standard power shutdown sequence must be carried out as described in section 12.5.1.



Danger to life and limb! Appropriate safety precautions must be taken.

Only turn on the Track Supply when the track is connected and the covers closed.

Do not use the main switch as a general power on/off switch, as this can damage the fuses in the Track Supply.

Work safely: always disconnect the power cable from voltage!

Track Supply 35 kW 80 / 125 A at 400 / 480 V

10 Fuses

10.1 Mains Semiconductor Fuses

Used fuses see chapter 21.



Attention: The Track Supply is without any voltage inside only when the plug or the power supply is disconnected for at least 20 minutes. After 10 minutes the voltages on the main bus capacitors have dropped to < 60 Vdc.



Semiconductor main fuses



When checking and changing of the main fuses please follow these instructions:



- Disconnect the Track Supply from power and secure it against being restarted or turned back on.
- Before opening the Track Supply, wait at least 10 minutes to allow internally stored voltage (capacitors) to drop to < 60 V direct current.
- Remove the fuse cover (left cover).
- After removal, check the condition of the fuses!
- If any of the fuses need replacement, change all 3 fuses together
- Replace the cover and return the Track Supply to operation!
- Connect the Track Supply to the mains voltage and re-start!

Track Supply 35 kW

80 / 125 A at 400 / 480 V

10.2 Other Protection Devices (Fuses)



The Track Supply does contain other small fuses and circuit-breakers but changing these without consulting Conductix-Wampfler is not recommended.

In case of repair the Track Supply must be disconnected from the mains supply and adequate discharging time (at least 10 minutes to reduce voltages to < 60Vdc) must be observed. Do not attempt to the reset auxiliary circuit breaker (see photo top left) while the Track Supply is connected to the mains.

11 Transport and Storage



The transport company must be advised about any damage that has been detected after delivery. Prior to installing or starting operation of damaged components please consult the supplier.

The Track Supply must only be moved, lifted or carried by suitable lifting and transport equipment (Weight see chapter 6.4 "Mechanical data"). Pay attention to the additional weight on side.

When using a forklift or similar transport equipment take care not to damage the cabinet. If you move the Track Supply by crane or other lifting equipment please use the four thread inserts to attach the lifting rope to the Track Supply. Follow the instructions of your lifting gear to lift correctly and safely. Pay attention to the respective equipment operating instructions for lifting and transport.

Regarding storage conditions please see chapter 6.3 "Environmental data".

12 Installation

12.1 Who is authorized to carry out the Installation?



All installation and commissioning work as well as maintenance work and disassembly have to be carried out by qualified staff (IEC 364 respectively CENELEC HD 384 or DIN VDE 0100 and IEC 664 or DIN VDE 0110 and national safety rules).



All installation and commissioning work have to be done according to the present operation manual. The specifications of this document have to be strictly observed. In addition, national regulations and whenever they apply regulations specific to the industry are to be taken into account.



Qualified staff according to the safety regulations are persons who are familiar with the assembly and installation of the energy supply system and who have the appropriate qualifications.

12.2 General Advice for the Installation



- After receipt of the component(s) and prior to starting the installation work, unpack the component(s) and check carefully for damage that may have occurred during transport or storage (damage to housings and insulation, missing parts etc.).
- Check data on the identification plate to make sure that the component(s) meet the requirements with regard to nominal power and voltage.
- Check completeness of the documents and conformity with the delivered component(s).
- When operating several track supplies in one plant the control board may need to be synchronized. Conductix-Wampfler provides documentation with the synchronization components.



For the installation of the Track Supply make sure that it is positioned safely and on an even surface. It has to be secured on site so that the position of the Track Supply will be permanently safe! The Track Supply center of gravity is offset relative to the middle of the base. Follow the cabinet manufacturer's instructions to fix the cabinet on floor. Use only components recommended by the manufacturer to fix the cabinet!

An improper installation of the energy supply system has a negative effect on its function, efficiency and lifetime. It is therefore important to observe the specification for the choice of the place of installation. The guarantee will expire if this is not observed!

Follow the instructions for fixing the cabinet of the Track Supply to the base and make the grounding according to description in chapter 6.9 "Grounding".

Track Supply 35 kW 80 / 125 A at 400 / 480 V

12.3 Place and Conditions of Installation



Always install the Track Supply in a dry and ventilated room. The Track Supply has to be mounted in a vertical position and attached to a solid base or wall construction.



The heat loss of the Track Supply is mainly ventilated out of the housing by forced convection cooling or rather by the air conditioning unit. It is therefore essential to make sure during the mounting that the air flow is not hindered in any way by objects near the inlet or outlet of the housing – see chapter 7 “Optional configurable Air Conditioning Unit (mounted on the Side)”.

The ambient temperature should not be lower than 5°C and must not exceed the Conductix-Wampller specification of 40°C. The relative air humidity should be below 90% and there must not be any condensation. Avoid negative influences of the environment.

Operation outside of these conditions can cause changes of the power parameters. (Take notice of the chapter 6 “Technical data”.)

In case the Track Supply is installed in a cabinet or small room, a sufficient air flow must be ensured. The temperature inside the cabinet shall not exceed 40°C. Install filters and/or air-conditioning in order to meet the necessary IP protection classification.

The climatic conditions for storage and operation according to the specifications have to be observed - see chapter 6.3 “Environmental data”.

A distance of 100 mm between the sides and the back of the cabinet to walls and other cabinets and a distance of 400 mm from the air conditioning unit is recommended for maximum performance, especially if neighboring equipment is also generating heat.

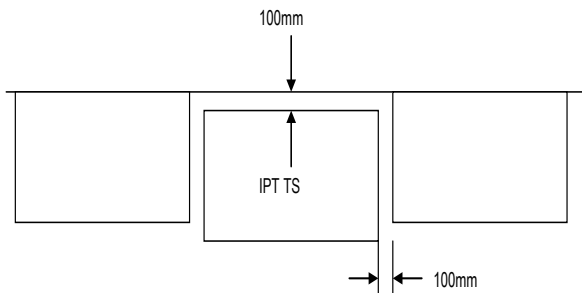

Top view of Track Supply positional placement
(Type without Air Cond.)

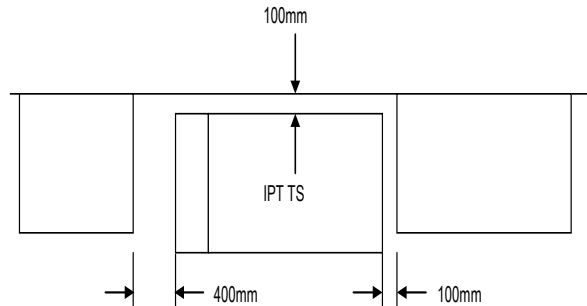

Top view of Track Supply positional placement
(Type with Air Cond.)

Track Supply 35 kW

80 / 125 A at 400 / 480 V

12.4 Electrical Regulations

The general electrical operating conditions according to VDE 0100 (installation and operation of electrical equipment up to 1000 V) have to be observed. If necessary observe the local regulations when they go beyond these requirements.

The internal fuses in the Track Supply are for limiting damage within the Track Supply in the event of a component failure.

Appropriate protection should be given to the three-phase supply cable according to local regulations.

12.5 Electrical Connection

12.5.1 Mains Connection

The power cables of the supply lines L1, L2, L3 and PE have to be chosen as follows:

1. Use only applicable cables that are approved according to VDE, UL or CUL.
2. The Track Supply is designed for connection to a neutral grounded 3-phase supply system. Other connection variants must be discussed in advance with Conductix-Wampfler.
3. The nominal voltage of the cables for systems of 480 V AC must be at least 600 V.
4. The core cross-section has to be planned according to the relevant standards but recommended is 10 mm².
5. Grounding is to realize according to VDE, NEC and IEC (see chapter 6.9 "Grounding").
6. The 3-phase input supply connection to X2 requires a flexible stranded core type cable for connection to the supplied Harting connector. Maximum cable outer diameter is 25 mm with supplied Pg 29 cable gland. Larger HAN 6 connectors with M40 x 1.5 cable gland entry for larger cables are also available from the manufacturer HARTING. These may be required for cables used in longer cable runs.
7. For supply voltages other than specified please consult Conductix-Wampfler about changing the tap setting on the internal step-down control transformer, which has +5% tap settings, for better compatibility.

Attention!

To avoid damaging the input fuses we recommend that the 3 phase mains supply shall be only removed when the START / STOP-signal is in the "STOP" position. A delay of at least 0.5 seconds should always be ensured.

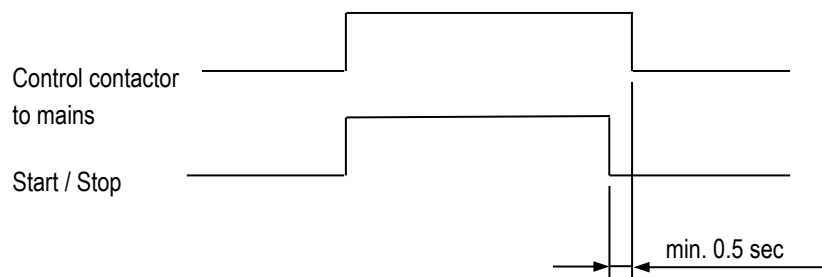

Track Supply 35 kW 80 / 125 A at 400 / 480 V

12.5.2 Configuration of control plug

Inputs:	/Reset	Reset+ (Pin 3) must be taken 24 V DC above Reset - (Pin 4), otherwise the Track Supply remains in a reset state. Note: to reset the Track Supply, Reset must go low for at least 0.5 seconds.
	Start	The Track Supply can only be turned on if the 24 V signal is applied continuously on Pin 1 and Pin 2.
	Sync	For synchronizing track supplies together to the same frequency and phase. Use only Conductix-Wampfler approved equipment. When using several track supplies synchronization may be required.



Even if no start signal is applied, some parts inside the Track Supply may be live.

Both Start and Reset inputs are optically isolated and may be connected to an external 24 V DC supply or the 24 V output provided.

Outputs:	Error	Switch is open on error or if the mains supply is disconnected. Otherwise it is closed.
	0 and 24 V	May be used for control and commissioning, but must not be distributed over cables longer than 2 m. Only for use by the commissioning technician during commissioning! Other use is prohibited.

Reference for input and output:

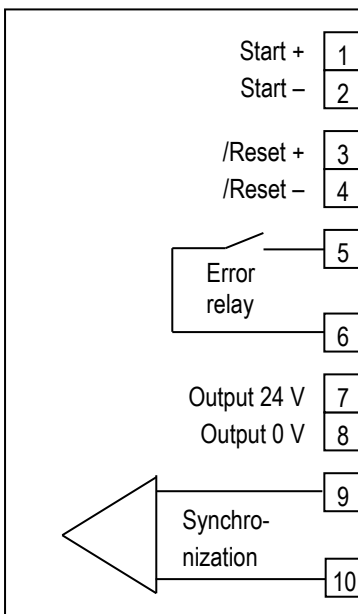

Harting HAN 10E

Track Supply 35 kW 80 / 125 A at 400 / 480 V



Do not locally distribute this 24 V DC supply output over control cables! Do not reference 0 V to other potentials!

Only for use by the commissioning technician during commissioning! Other use is prohibited.



If the Reset signal is given as soon as there is a fault, the information about the fault code is deleted on the display.

HINWEIS!

12.5.3 Connection Track Cable (X1)

Tightening torque for the X1.1 and X1.2 connection terminals of the track cables: 9-10 Nm

Torque has to be checked frequently.

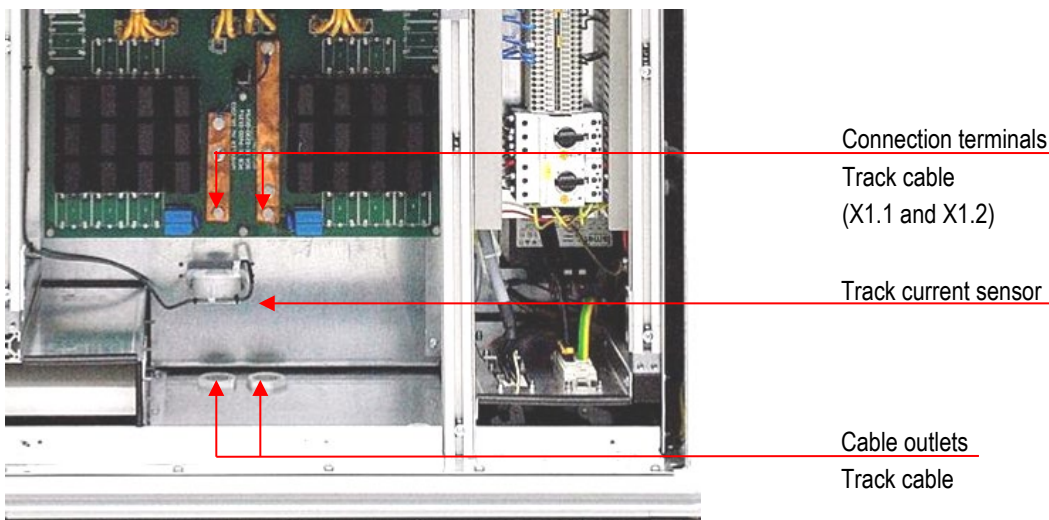

12.5.4 Arrangement external Connections (X1, X2, X3, X5.1)

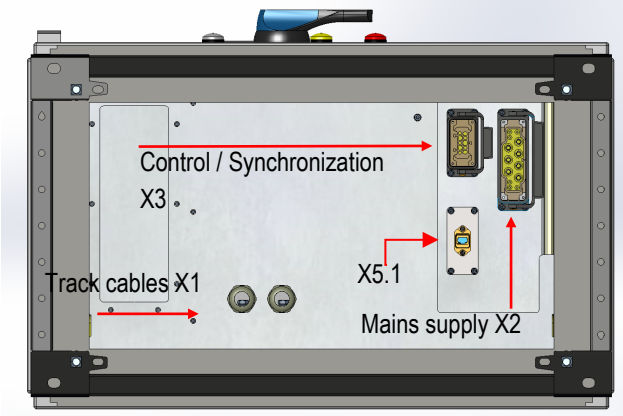

Track Supply 35 kW 80 / 125 A at 400 / 480 V

Cabinet underneath

Hint: Pay attention to leaving cable ends long enough to make connections. We recommend to use a highly flexible cable!

View with dimensions in the cabinet - underneath

- 3090896 (80 A, 400 V,)
- 3090899 (80 A, 480 V,)
- 3090897 (125 A, 400 V,)
- 3090900 (125 A, 480 V,)

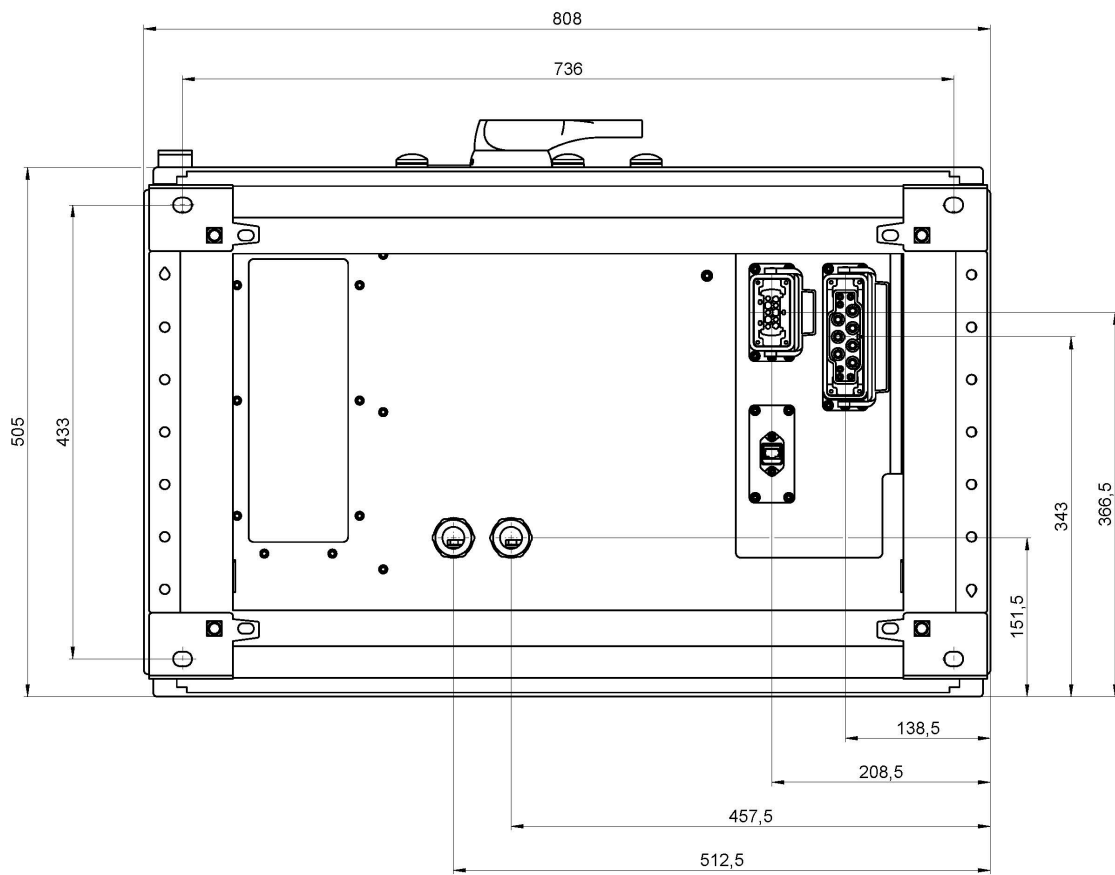

Door switch = front side

Track Supply 35 kW
80 / 125 A at 400 / 480 V

3090901 (configurable version)

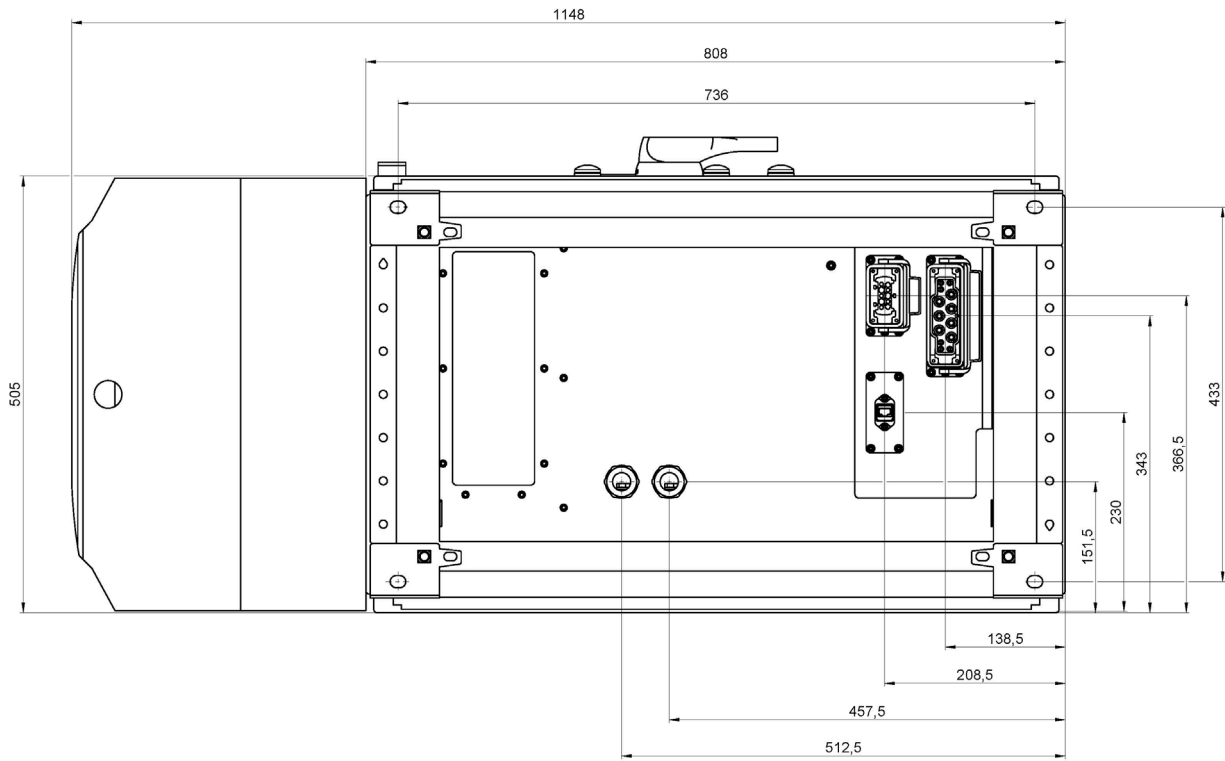

Door switch = front side

Track Supply 35 kW
80 / 125 A at 400 / 480 V

12.5.5 Wiring of the Track Supply

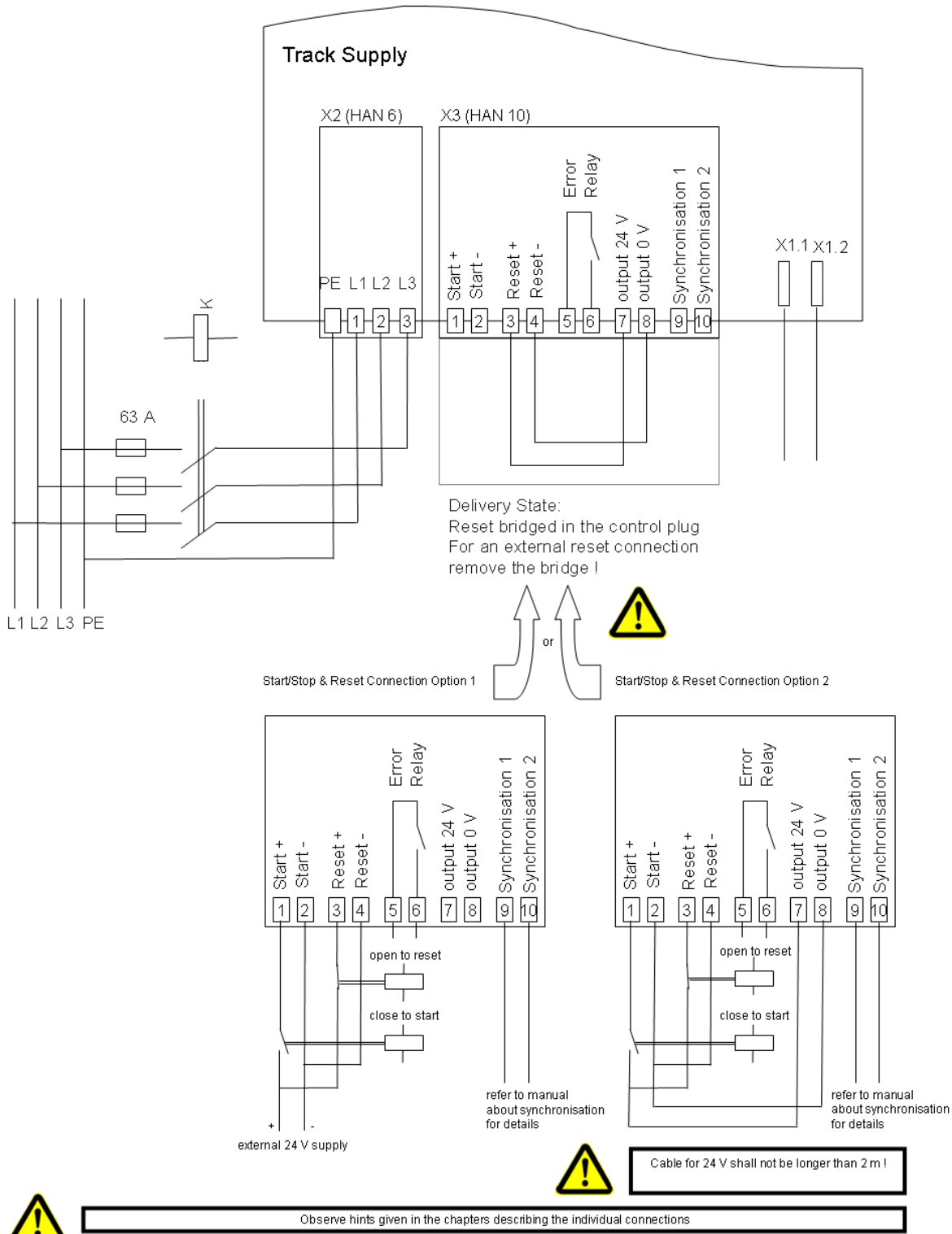

Track Supply 35 kW

80 / 125 A at 400 / 480 V

13 Warnings and cautions



All electric works have to be carried out by qualified staff (IEC 364 respectively CENELEC HD 384 or DIN VDE 0100 and IEC 664 or DIN VDE 0110 and national safety rules).



All installation and commissioning work as well as repair work and disassembly have to be done according to the present operation manual. The specifications of this document have to be strictly observed. In addition, national regulations and whenever they apply regulations specific to the industry are to be taken into account.



Qualified staff according to the safety regulations are persons who are familiar with the installation, commissioning and operation of the energy supply systems and who have the appropriate qualifications.

The Track Supply is only foreseen to be operated in conjunction with matching components. If you are not sure whether components match, contact Conductix-Wamplfer. Do not put into operation beforehand.

Operation of the Track Supply without all provided covers may allow the ingress of dirt and dust, thereby reducing the ability to function reliably and within specification. Avoid operation with removed cover(s) and / or opened door.

Tighten all cable glands at the bottom of the inner enclosure and ensure that the polycarbonate cover is screwed down properly! All cable connections inside the housing have to be fixed.

Although the Track Supply output is isolated from the mains supply by a transformer, the 20 kHz high frequency output is Protective Earth referenced by Y-connected noise suppressing capacitors. This means a potential voltage exists with respect to PE that could cause electric shock and even death in some people.

Avoid coming into contact with any uninsulated part of the primary supply. Don't touch electrical components in the Track Supply.

DANGER OF LIFE MUST BE AVOIDED BY IMPLEMENTING SUITABLE PROTECTION MEASURES!

Observe safety pre-cautions before and while removing any covers and housings!

Track Supply 35 kW

80 / 125 A at 400 / 480 V

14 Commissioning

Prior to commissioning pay attention to warnings and hints in chapter 13 “Warnings and cautions”.



Track supplies have to be commissioned in conjunction with other corresponding Rail components. For commissioning it is thus necessary to have the secondary components installed on the vehicles. Access to the secondary side pickups and power regulators on vehicles is necessary.



The primary system has to be installed completely before commissioning. Commissioning on site requires adjustment of the primary track cable impedance that the Track Supply is connected to. The general operation of the inductive energy supply, with regard to the required resonant conditions of the system, is adjusted to the local conditions by means of capacitors and inductors.

These adjustments at the Track Supply must be done only by trained personnel.

During commissioning work the dangerous work zone has to be provided with warning signs and secured with a shutoff tape against entry by unauthorized persons to the site or touching of current-carrying parts.

Requirements for the commissioning:

- Entrance to the site without any problems.
- Free access to the power supply without any difficulties.
- Free access to all components.
- Safe storage for all needed tools (components, tools, measurement equipment, utilities etc.)
- Possibility to remove or to short-out pickup(s).
- Possibility to increase the load on the pickup(s) / power regulator(s) step by step.
- Access to external control signals to the Track Supply.

Any changes to the system (e.g. more vehicles) or in the environment after the commissioning require an additional commissioning.

Track Supply 35 kW 80 / 125 A at 400 / 480 V

14.1 System conditions

The permissible transient fluctuation of the mains voltage is between -15% and +10% of the nominal voltage. If the values are lower or higher than these, the technical specifications of the Track Supply can no longer be guaranteed and the power feed convert can be damaged.

To protect the semiconductors from voltage transients, varistors are installed in the Track Supply as a protective mechanism for the power electronic components, as shown in the following sketch. If the power feed does not comply with the manufacturer specifications for the varistor types listed below (EPCOS/TKD B72220P3301K or similar), there is a risk that the electronic components of the Track Supply could be destroyed

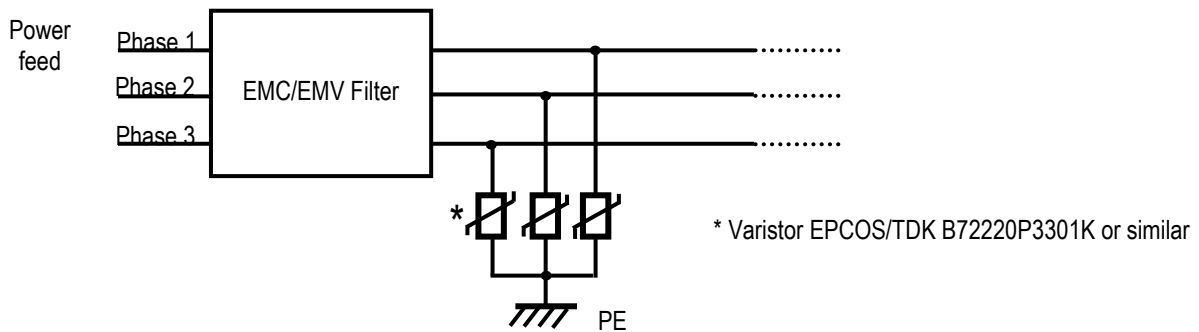

Schematic

14.2 System protection

The user must install fuses or overload disconnectors in the power input line according to the relevant regulations of the NEC and all local regulations. The operation level must be coordinated with the internal 80 A fusing of the Track Supply.

Track Supply 35 kW

80 / 125 A at 400 / 480 V

15 Start and operation



The Track Supply is not designed for independent operation. It has to be operated in conjunction with corresponding rail components. Therefore no specific details about the operation are given in this document.



Prior to switching-on the Track Supply ensure that the installation and commissioning were executed correctly. Always attend to the valid safety regulations!

After connecting the Track Supply to the line voltage the components of the power circuit are connected to the voltage network. Do not touch these components. **DANGER OF LIFE!** It is therefore obligatory to keep all doors and covers CLOSED.

Start-Sequence (remote operation):

1. If there is an external isolator switch between net distribution and Track Supply switch it on now.
2. Switch-on the Track Supply - "ON" on the START-input.
3. On the control board the green "ON" LED is on.
4. The System is now on.

Prior to any intervention into an electrical or mechanical component of the energy supply system the complete system always has to be disconnected from the supply voltage!

Connecting and disconnecting measuring instruments is only allowed under off-circuit conditions and must only be carried out by trained personnel.

Reconstruction or modifications at the energy supply system or its components on one's own authority are excluded from the guarantee.

Any necessary reconstructions or modifications - especially on electrical components - are only allowed if they have been approved by Conductix-Wampller.

Track Supply 35 kW

80 / 125 A at 400 / 480 V

16 Switching-off



As described earlier (see chapter 12.5 “Electrical connection”): first switch-off the Track Supply by switching the START-input to “OFF” and after this disconnect the line voltage (i.e. by a load switch). The system should be turned off using the load-break switch only in exceptional cases (see also Chapter 9 Main door switch).



After disconnection of the energy supply system from the supply voltage, components or power terminals must not be touched immediately afterwards, because capacitors might be charged. Before starting work with the power supply system or its components, wait at least 10 minutes to allow internally stored voltage (capacitors) to drop to < 60 V direct current.

Component lifetime may be extended by turning off the Track Supply when the System is not needed, for instance during the night or on weekends.

17 Actions in case of emergency



In the case of smoke inside the cabinet, sparking or danger to personnel or equipment, immediately disconnect the Track Supply from the main supply by first switching off the isolating switch on the door to “OFF”. As a secondary measure disconnect the HAN K6/6 Power Plug.



Unauthorized switching on by a third person has to be prevented by removing the line fuses of the main supply or by other adequate measures on site.



After turning off the Track Supply, wait at least 10 minutes to allow internally stored voltage (capacitors) to drop to < 60 V direct current **before** opening the cabinet and starting work on the power supply system.

The dangerous zone has to be provided with warning signs and secured with a shutoff tape against entry by unauthorized people.

Track Supply 35 kW 80 / 125 A at 400 / 480 V

18 Fault diagnosis



If the Track Supply faults - e.g. no energy supply to the secondary components, check the LED display for indication of possible cause. Refer to chapter 8 "Control board hardware and failure indication" for LED status.



Attempts to repair or restart should be avoided! Do not use the system anymore as long as the error is not located and repaired or defect components are replaced by trained personal!

After conclusion of the failure analysis the Track Supply has to be protected against touching of live parts by closed housing/covers (see Safety hints in chapter 12.2 „General advice for the installation“).

Failure indication on the outside

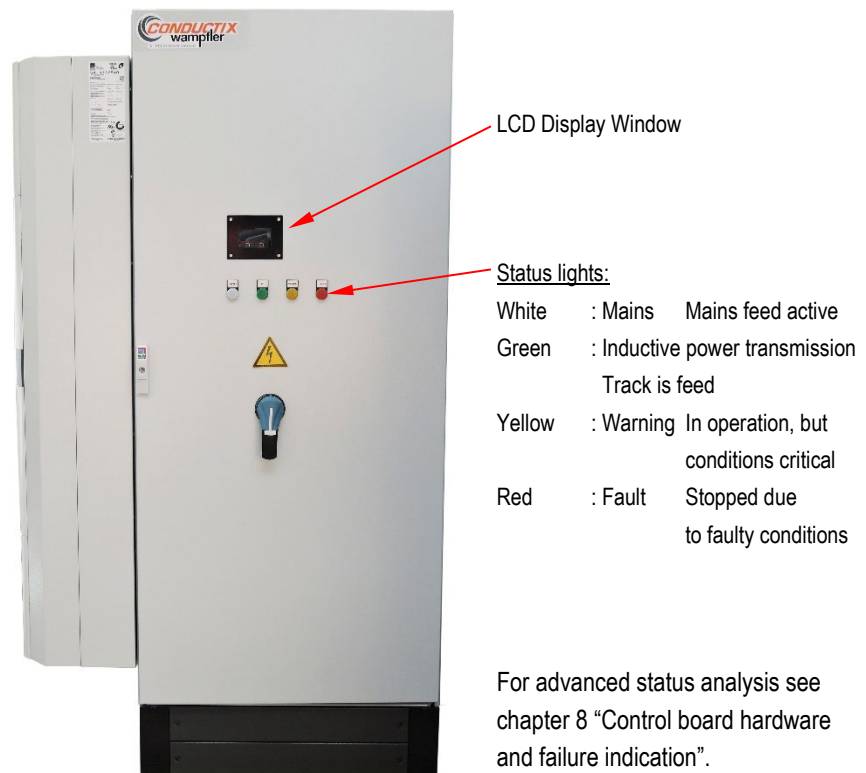

Figure shows configurable version with optional air conditioning

Regarding the failure indication of the air conditioning unit please use the producer documentation.

19 Maintenance

19.1 Safety



WARNING!

Danger of injury due to improperly executed maintenance tasks!

Improper maintenance can result in serious personnel injury or property damage.

- Before starting work, ensure that there is sufficient space for assembly.
- Maintain order and cleanliness in the assembly area! Loosely stacked or scattered components and tools are a source of accidents.
- If components have been removed, be careful to reinstall them properly, replace all fastening elements, and observe screw tightening torques.



WARNING!

Risk of injury due to insufficient qualification!

Improper use can result in serious injury to persons or property damage.

- All works for installation and commissioning as well as for maintenance and disassembly must be carried out by qualified staff (observe IEC 364 resp. CENELEC HD 384 or DIN VDE 0100 and IEC 664 or DIN VDE 0110 and the national accident prevention regulations).
- All works for installation and commissioning must be carried out according to these mounting instructions. All the notes listed in this document must be strictly observed. It is moreover required to observe the general national prescriptions and specific factory regulations.

Adjustments concerning inductivity may only be made by qualified personnel of Conductix-Wampller.



NOTE!

Qualified personnel, according to the safety regulations, are persons that are familiar with the installation, assembly, commissioning and operation of energy supply systems and that have the appropriate qualifications.

19.2 Maintenance Schedule Track Supply IP54 (air cooling)

The tasks carried out according to the maintenance schedule must be logged. If regular inspections reveal increased wear, the corresponding maintenance intervals should be shortened in accordance with the actual signs of wear. In case of any questions regarding maintenance tasks and intervals, contact the manufacturer; see service address on the last page.



DANGER!

Danger of electric shock!

During maintenance and repair work the Track Supply must be secured against unexpected and unintended switch on.

- Prior to starting maintenance works disconnect the Track Supply from the mains supply!
- Do not make any structural changes! Always contact Conductix-Wampller.

The following maintenance work should be carried out every 3 months:

Track Supply 35 kW

80 / 125 A at 400 / 480 V

- Check cables and terminals for wear and tear (mechanical damage, high temperatures)
- Visual inspection for external damage and damage due to special ambient conditions (e.g. damage of the housing cover, splash water, oil etc.)
- Inlet and outlet air are free - free airflow must be ensured. Ensure that the airflow and the air ducts are not blocked by any objects. Polluted filter pads - must be replaced by new ones.
- Ensure that the Track Supply is dry, clean and free from dust and oil. If the Track Supply is very dirty, check the IP-protection and contact Conductix-Wampfler regarding appropriate cleaning measures.
- Ensure that all connections are firmly tightened.
- Make sure that all plugs are in the right place.



NOTE!

The Track Supply is equipped with a standard filter for normal indoor environment. There are finer filters on the market, if required. We recommend the exclusive use of original filter by Rittal. In very challenging/dirty environment we recommend the installation of an air conditioned Track Supply IP54.



NOTE!

Generally it is recommended to apply maintenance at least every 6 month. If the operating conditions are challenging and the environment is not clean, Conductix-Wampfler recommends shorter intervals than 6 months.

For a qualified check of the operating parameters of the system, please contact Conductix-Wampfler. Thus you can compare the currently measured values with those obtained during commissioning or the last inspection. Here you can also check free airflow inside the housing and specific torques.



WARNING!

Risk of personal injury of property damage!

Improper attachment of the housing cover can cause severe injuries to persons or damage to components.

- After having completed the maintenance and repair works, close the housing covers again, prior to restarting the system.

19.3 Maintenance Schedule Track Supply IP54 (air cooling)

The tasks carried out according to the maintenance schedule must be logged. If regular inspections reveal increased wear, the corresponding maintenance intervals should be shortened in accordance with the actual signs of wear. In case of any questions regarding maintenance tasks and intervals, contact the manufacturer; see service address on the last page.



DANGER!

Danger of electric shock!

During maintenance and repair work the Track Supply must be secured against unexpected and unintended switch on.

- Prior to starting maintenance works disconnect the Track Supply from the mains supply!
- Do not make any structural changes! Always contact Conductix-Wampfler.

Track Supply 35 kW

80 / 125 A at 400 / 480 V

The following maintenance and inspection works should be carried out every 3 months:

- Check cables and terminals for wear and tear (mechanical damage, high temperatures)
- Visual inspection for external damage and damage due to special ambient conditions (e.g. damage of the housing cover, splash water, oil etc.)
- Inlet and outlet air are free - free airflow must be ensured. Ensure that the airflow and the air ducts are not blocked by any objects. Air conditioning unit must be maintained in accordance with the maintenance instructions of the manufacturer of the air-conditioning unit.
- Ensure that the Track Supply is dry, clean and free from dust and oil. If the Track Supply is very dirty, check the IP-protection and contact Conductix-Wampfler regarding appropriate cleaning measures.
- Ensure that all connections are firmly tightened.
- Make sure that all plugs are in the right place.



NOTE!

The Track Supply is equipped with a standard filter for normal indoor environment. If required, you will also find metal filters on the market for ambient conditions with oil-containing air. We recommend the exclusive use of original filters by Rittal.



NOTE!

If the operating conditions are challenging and the environment is not clean, Conductix-Wampfler recommends shorter intervals of max. 6 months.



NOTE!

For the maintenance of the air-conditioning system, see the documentation of the manufacturer (Rittal).

For a qualified check of the operating parameters of the system, please contact Conductix-Wampfler. Thus you can compare the currently measured values with those obtained during commissioning or the last inspection. Here you can also check free airflow inside the housing and specific torques.



NOTE!

Refill and replacement of coolant only by qualified and authorized personnel! Disposal of the coolant may only be carried out by a specialist company!



WARNING!

Risk of personal injury of property damage!

Improper attachment of the housing cover can cause severe injuries to persons or damage to components.

- After having completed the maintenance and repair works, close the housing covers again, prior to restarting the system.

Track Supply 35 kW

80 / 125 A at 400 / 480 V

20 Repair



If repair action or replacement of faulty parts is necessary and possible on site these works have to be carried out only by trained personnel or by a Conductix-Wampfler technician, both while considering the relevant safety regulations. If no failure analysis or repair is possible on site the faulty part has to be sent to Conductix-Wampfler GmbH. Please inform our service department in this case for details.

To decide which procedure is the best in your case please inform us of the following:

- Product designation
- Material number
- Serial number
- Configuration details (in case)
- Line data (technical and line-specific)
- Wiring scheme of the line / unit (if available)
- Pictures / photos (if available)
- Failure description or details about the malfunction
- Presumption for the failure analysis

The general and local safety regulations have to be observed (see chapter 12 "Installation" and chapter 13 "Warnings and cautions").

21 Disassembly/Re-use



If it is necessary to exchange the Track Supply due to damage or to install it in another place, verify that no damage can occur during disassembly.

For installation in another place observe the described mounting and commissioning instructions. Improper application, wrong installation or operation involves the risk of severe injuries to persons and damage to objects.

All electrical work has to be carried out by qualified staff (IEC 364 respectively. CENELEC HD 384 or DIN VDE 0100 and IEC 664 or DIN VDE 0110 and national safety rules).

Qualified staff according to the safety regulations are persons who are familiar with the installation, assembly, commissioning and operation of the energy supply system and who have the appropriate qualifications.

Track Supply 35 kW

80 / 125 A at 400 / 480 V

21.1 Safety advice for disassembly and disposal



Avoid any personal and environmental hazard caused by opening of the components!



1. Disconnect unit from the mains voltage.
2. After disconnecting the Track Supply from mains voltage, wait at least 10 minutes to allow internally stored voltage (capacitors) to drop to < 60 V direct current before opening the Track Supply.
3. Dismount the Track Supply.
4. Dispose of components in a specific way. → Recycling (see chapter 21.2)
5. Please pay special attention to the manufacturer's instructions of the air conditioning unit for disassembly and disposal.

21.2 Recycling



The unit contains components that have to be disposed of in a specific way. If it is not used any longer, it needs to be recycled properly.

Please pay special attention to the manufacturer's instructions of the air conditioning unit for recycling.

Track Supply 35 kW 80 / 125 A at 400 / 480 V

22 Spare parts

Only the fuses and a few other parts are to be changed by the operator of the plant! All other parts have to be changed or repaired by trained and qualified Conductix-Wampfler personnel.

Designation	Producer Identification	Conductix-Wampfler Mat.-No.	Used quantity	Remarks
Cylindrical Fuse 80 A, 660 V, 22x58	Bussmann 170L2217 or 170N2280 Alternative-Type: <ul style="list-style-type: none"> Ferraz-Shawmut AO70URD30KI0080 (UL recognized, 700 V, 80 A) Siba 50.148.06-80 (UL recognized, 660 V, 80 A) 	3019461	3	For 400 V versions only! Replacement only by qualified personnel
Fuse 80 A, 700 V Fuserbloc TYPE J UR/UL	Bussmann FWP-80B Alternativ-Type: <ul style="list-style-type: none"> Ferraz Shawmut AO70URD30KI0080 (UL recognized, 700 V, 80 A) Siba 50.148.06-80 (UL recognized, 660 V, 80 A) 	3017732	3	For 480 V versions only! Replacement only by qualified personnel
Control board replacement set 35 kW 400 V 80 A		3182512	1	For 480 V 80 A versions only! Replacement only by qualified Conductix-Wampfler personnel.
Control board replacement set 35 kW 400 V 125 A		3182511	1	For 480 V 125 A versions only! Replacement only by qualified Conductix-Wampfler personnel.

Track Supply 35 kW 80 / 125 A at 400 / 480 V

Designation	Producer Identification	Conductix-Wampfler Mat.-No.	Used quantity	Remarks
Control board replacement set 35 KW 80 V 125 A		3182515	1	For 400 V 80 A versions only! Only by qualified Conductix-Wampfler personnel
Control board replacement set 35 KW 480 V 125 A		3182514	1	For 480 V 125 A versions only! Only by qualified Conductix-Wampfler personnel
Power module G4 TS 35 KW 400V TS 35 kW		3092122	1	For 400 V versions only! Replacement and configuration only by qualified Conductix-Wampfler personnel.
Power module G4 TS 35 KW 480V TS 35 kW		3092123	1	For 480 V versions only! Replacement and configuration only by qualified Conductix-Wampfler personnel.
Fan unit TS 35 kW G4		3131213	1	Replacement only by qualified personnel
Air Conditioning* RAL7035	Rittal SK 3332540		1	
External Ethernet plug PLUG CONNECTOR RJ45 CAT5 IP65 SHIELDED	Han PP V14 RJ45 Cat5 Stvb 4p IDC Cat5 Stvb 4p IDC 6.5-9.5 Art.-Nr. 09352210421			For use with Industrial Ethernet

*= Spares and wear parts for the air conditioning unit you find in the producer documentation.

Other on request

Track Supply 35 kW 80 / 125 A at 400 / 480 V

23 Tools



Description	Size / specification	Remarks
Open ended or ring spanner wrench	SW 13	Connection track cable (20 and 35 mm ² Litz cable)
Hex Allen Key	4 mm	Plug HAN K6/6
Flat Screw driver	3 - 4 mm	Plug HAN-6HSB and HAN-10E
Cable end sleeves	0.5 – 2.5 mm ²	Plug HAN-10E
Crimper for cable end sleeves	0.5 – 2.5 mm ²	-
Tools to strip the cables	-	-
Side Cutter	-	-

Switching cabinet: For special tools or further details see hints from the producer Rittal GmbH & Co. KG.

Air conditioning unit: For special tools or further details see hints from the producer Rittal GmbH & Co. KG.

For the commissioning further tools and measuring instruments are needed.

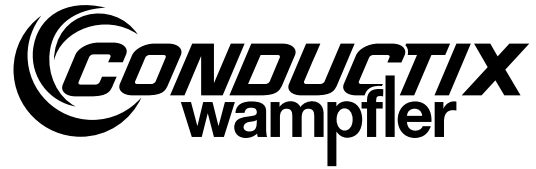

Track Supply 35 kW
80 / 125 A at 400 / 480 V

24 Adjustments during the commissioning and start-up

Track Supply ____ A ____ V @ ____ Hz

Material-No.: _____

Serial number

Name of the project or line

Environmental conditions on the place

Following values were measured or adjusted:

Inductance without track tuning / Adjustment (μH)

Inductance after track tuning / Adjustment (μH)

Output voltage - track (V)

Output current (A)

Inverter current (A)

Input line supply (V)

Adjusted switch-point Air Conditioning unit ON..... OFF.....

Remarks / Hints:

.....
.....

Recommended date for the next inspection:

.....
Date

.....
Name

.....
Sign

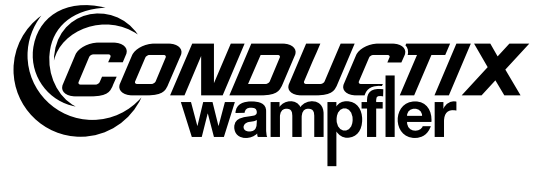

Track Supply 35 kW
80 / 125 A at 400 / 480 V

25 Inspection Report

Inspection report _____

Track Supply ____ A ____ V @ ____ Hz

Material-No.: _____

Serial number

Name of the project or line

Environmental conditions on the place

Following values were measured or adjusted:

Table with 3 columns: Last, Current, O.K. and rows for Inductance without track tuning, Inductance after track tuning, Output voltage - track, Output current, Inverter current, Input line supply, Adjusted switch-point Air Conditioning unit.

Remarks/Hints:

.....
.....

Recommended date for the next inspection:

State of the Track Supply: Ready for operation

.....
Date Name Signature

Track Supply 35 kW

80 / 125 A at 400 / 480 V

26 Additional Documents

Seq. No.	Document number	Document number
01	Manufacturer Documentation	Anybus Module
02	Manufacturer Documentation	Air Condition Unit
03	Conductix-Wampler TI9100-0075	Track Supply Anybus

Conductix-Wampfler GmbH
Rheinstraße 27 + 33
79576 Weil am Rhein - Märkt
Germany

Phone: +49 (0) 7621 662-0
Fax: +49 (0) 7621 662-144
info.de@conductix.com
www.conductix.com



Importer for the United Kingdom:
Conductix-Wampfler Ltd.
1, Michigan Avenue
Salford
M50 2GY
United Kingdom

Phone: +44 161 8480161
Fax: +44 161 8737017
info.uk@conductix.com
www.conductix.com